

SPECIAL PRECAUTIONS

For All Schier Grease Interceptor Installations

Installation Instructions
Installation instructions and additional components are located inside the interceptor. Read all instructions prior to installation. This interceptor is intended to be installed by a licensed plumber in conformance with all local codes.

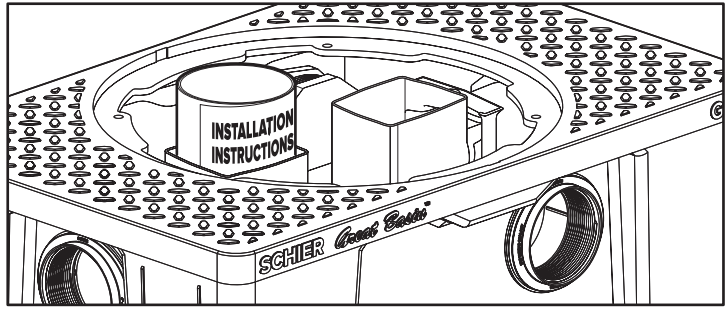

When Installing Interceptor Inside
If your dishwashing sink(s) discharges into a floor drain/sink (drain), you must regulate the flow into the drain to avoid an overflow of water onto the kitchen floor. This can be done by installing a valve or flow restriction cap on the sink piping that discharges into the drain. See drawing below for guidance. For detailed guidance on indirect connections, go to: http://webtools.schierproducts.com/Technical_Data/Indirect_Connections.pdf

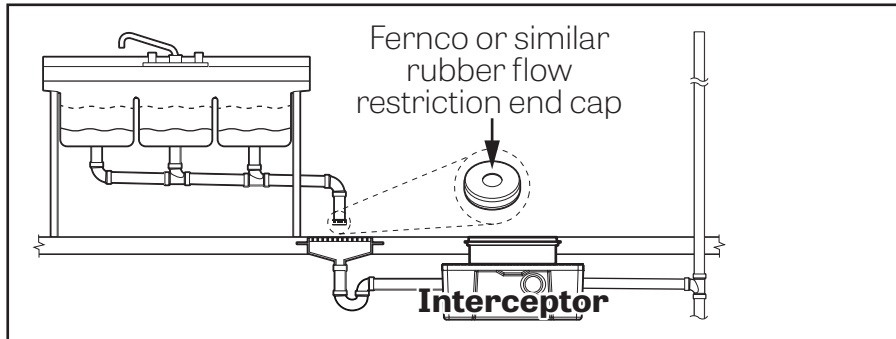

Hydrostatic Slabs (or Pressure Slabs)
When installed under a hydrostatic slab (slab designed to withstand upward lift, usually caused by hydrostatic pressure) interceptor must be enclosed in a watertight concrete vault. Failure to follow this guidance voids your warranty.

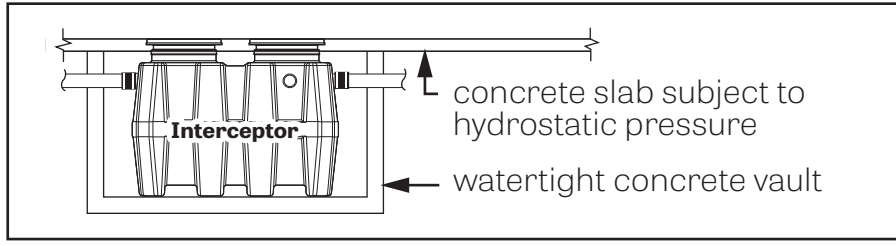

High Temperature Kitchen Water
If water is entering the interceptor at excessive temperature (over 140° F), a drain water tempering valve (DTV) must be installed. Most state and local plumbing codes prohibit water above 140° F being discharged into the sanitary sewer. Water above 140° F will weaken or deform PVC Schedule 40 pipe, poly drainage fixtures like interceptors and erode the coating of cast iron (leading to eventual failure). Failure to follow this guidance voids your warranty.

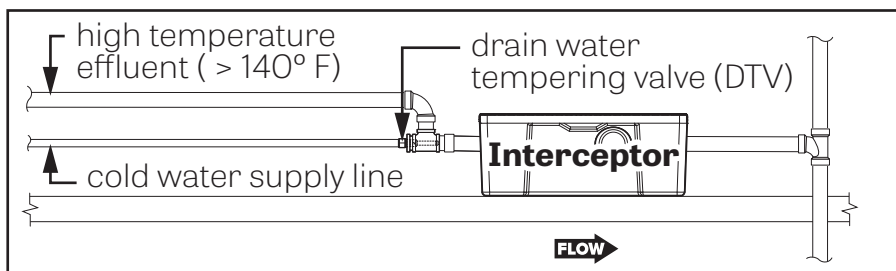

High Water Table Installations
Interceptors and risers are not designed to withstand water table height in excess of the top of the unit when buried (see figure). If it is possible for this to occur, install the interceptor and risers in a water-tight concrete vault or backfill with concrete or flowable fill (wet concrete and flowable backfill should be poured in stages to avoid crushing the interceptor). At risk areas include but are not limited to tidal surge areas, floodplains and areas that receive storm water. Failure to follow this guidance voids your warranty. Models GB-50, GB-75, and GB-250 that are direct buried in high water table scenarios must be installed with model AK1 anchor kit or warranty is void.

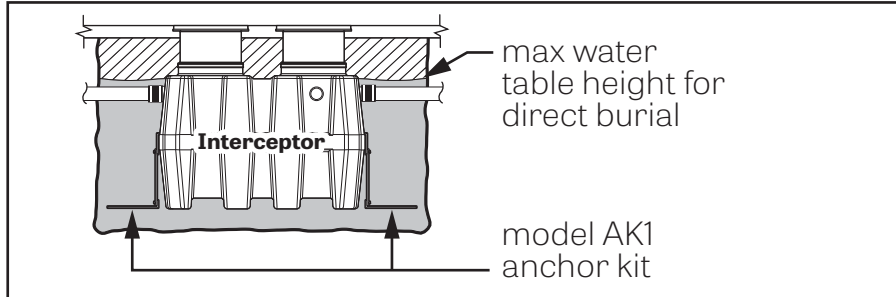

SPECIFICATIONS

- 6" plain end inlet/outlet
- Maximum flow rate: 314 GPM
- Liquid capacity: 1,500 gal.
- Unit weight w/std. covers: 1,200 lbs.
- Highway traffic load rated, bolted, gas/water tight composite covers. (16,000 lbs.)
- Maximum operating temperature: 140° F continuous
- Grease capacity: 1,620 lbs. (225 gal.)*
- Solids/sediment capacity: 150 gal.*

* Grease and solids capacities are based off the 25% Pump-out rule with 60% being grease and 40% being solids.

- NOTES:**
- Unit designed per UPC Z1001 construction guidelines. Do not use for pressure applications.
 - 3/4" thick seamless high density polyethylene walls.
 - Unit supplied with built-in adapters for up to 6" of adjustability. Additional risers available for deeper burial depth.
 - Cover placement allows full access to tank for proper maintenance.
 - Vent not required unless per local code.
 - Engineered inlet and outlet diffusers for ease of inspection and cleaning of piping.
 - For buried applications only.
 - Integral air relief / anti-siphon

DIFFUSION FLOW TECHNOLOGY:
The inlet diffuser splits influent into three paths, creating

laminar flow and utilizing the entire liquid volume of the tank for efficient grease separation. The calibrated openings greatly reduce effluent turbulence. The effluent enters the main chamber without disturbing the existing grease or sediment layers. The integral air relief / anti-siphon in the top of the outlet diffuser allows pressure stabilization within the unit during operation. The bottom of the outlet diffuser allows only effluent which is free of grease to exit the tank.

ENGINEER SPECIFICATION GUIDE:
Schier gravity grease interceptor model #GGI-1500 shall be lifetime guaranteed and made in USA of seamless high density polyethylene with minimum 3/4" uniform wall thickness. Interceptor shall be furnished for below grade installation with field adjustable riser system. Interceptor flow rate shall be 314 GPM. Interceptor grease capacity shall be 1,620 lbs. (225 gal.). Cover shall provide water/gas-tight seal and have minimum 16,000 lbs. load capacity with a safety factor of 2.

- OPTIONS:**
- C24-HP - H2O load rated pickable cast iron covers.
 - 4P 4" plain end SCH.40 connections
- TeleGlide Field Adjustable Riser System**
- SR24 (x2) 5" - 23"
 - LR24 (x2) >23" - 38"
 - SR24 (x4) >38" - 43"
 - SR24 (x2) + LR24 (x2) >43" - 58"
 - LR24 (x4) >58" - 72"

INSTALLATION INSTRUCTIONS

LEAK/SEAL TESTING:
! WARNING
DO NOT AIR TEST UNIT OR TELEGLIDE RISER SYSTEM! Doing so may result in property damage, personal injury or death.

Base Unit: To perform a leak/seal test on the base unit, cap/plug all plumbing connections, remove the cover, and fill the unit with water just above the highest connection. Inspect unit and connections for leaks. Check water level at specific time intervals per local code. **NOTE: All GGI series tanks have been wet tested for leaks prior to shipment from the factory.**

TeleGlide Riser System: If required by local code, the riser system may be leak/seal tested similar to the base unit. **CAUTION: the risers must be supported before filling with water to keep from tipping over.** Once the riser system is in place and properly supported, cap/plug all plumbing connections on the main unit, remove the cover from the top of the riser assembly and fill the unit and riser system with water to finished grade level. Carefully, as the risers will be very heavy from the weight of the water, inspect all gaskets and clamps (if applicable) for any leaks. Check water level at specific time intervals per local code.

- EXCAVATION**
- Install unit as close as possible to fixtures being serviced.
 - Surrounding soil must be undisturbed soil or well compacted engineering fill.
 - Measure the width and length of the tank and excavate a hole that is a minimum of 18" greater than the tank on all sides.
 - Depth of excavation shall be 12" deeper than tank bottom.
 - After the excavation is complete create a well compacted support layer of sand/gravel mixture so that ground supporting tank is a minimum of 12" above native soil.

- UNIT INSTALLATION**
- Lower and center the unit into hole using straps around unit. Do not use chains or accessways to move the unit.
 - Ensure the unit tops are level with finished grade.
 - All pipe penetrations to be sleeved or have slip connections.
 - Fill unit with water before backfilling to stabilize unit and prevent float-out during backfilling.

BACKFILLING AND FINISHED CONCRETE SLAB

- Before backfilling and pouring of slab, secure covers and risers (if necessary) to the unit.
- Backfill evenly all around tank using crushed aggregate material approximately 3/4" size rock, sand, with no fines. **Do not compact backfill around unit.**
- When backfilling ensure backfill is worked under the unit using a probe to ensure the unit is fully supported.
- Place 6" aggregate base under slab. Aggregate should be 3/4" size rock, sand, with no fines.
- Thickness of concrete around cover to be determined by specifying engineer. If traffic loading is required the concrete slab dimensions shown are for guideline purposes only.
- Concrete to be 28 day compressive strength to 4,000 PSI.
- NO. 4 rebar (ø 1/2") grade 60 steel per ASTM A615: connected with tie wire.
- Rebar to be 2 1/2" from edge of concrete.
- Rebar spacing 12" grid. 4" spacing around access openings

DEADMEN ANCHORING:

- Deadmen for high water table installation should be constructed according to the American Concrete Institute (ACI) code.
- Deadmen should be 12" wide x 12" tall and equal to the length of the entire unit.
- Deadmen should have 3 anchor points with turnbuckles and shall be corrosion resistant and rated for a minimum load capacity of 7,500 lbs.
- Lay the deadmen parallel with the unit and ensure that it is outside the shadow of the tank.
- Connect nylon strapping to each anchor point. Nylon straps must have a minimum load capacity of 7,500 lbs.

FOX METRO WATER RECLAMATION DISTRICT NOTES:

- Retrofit installations: A minimum of 42" of cover and a minimum of 1.00% slope is required for all exterior 4" and 6" piping.
- All pipe connections to the unit shall be made with non-shear couplers.
- Pipe type(s) installed upstream and downstream of unit as per the approved plan.
- Only CA-7 Class 1A stone shall be used 0'-6" under and 1'-0" over upstream and downstream sewers.

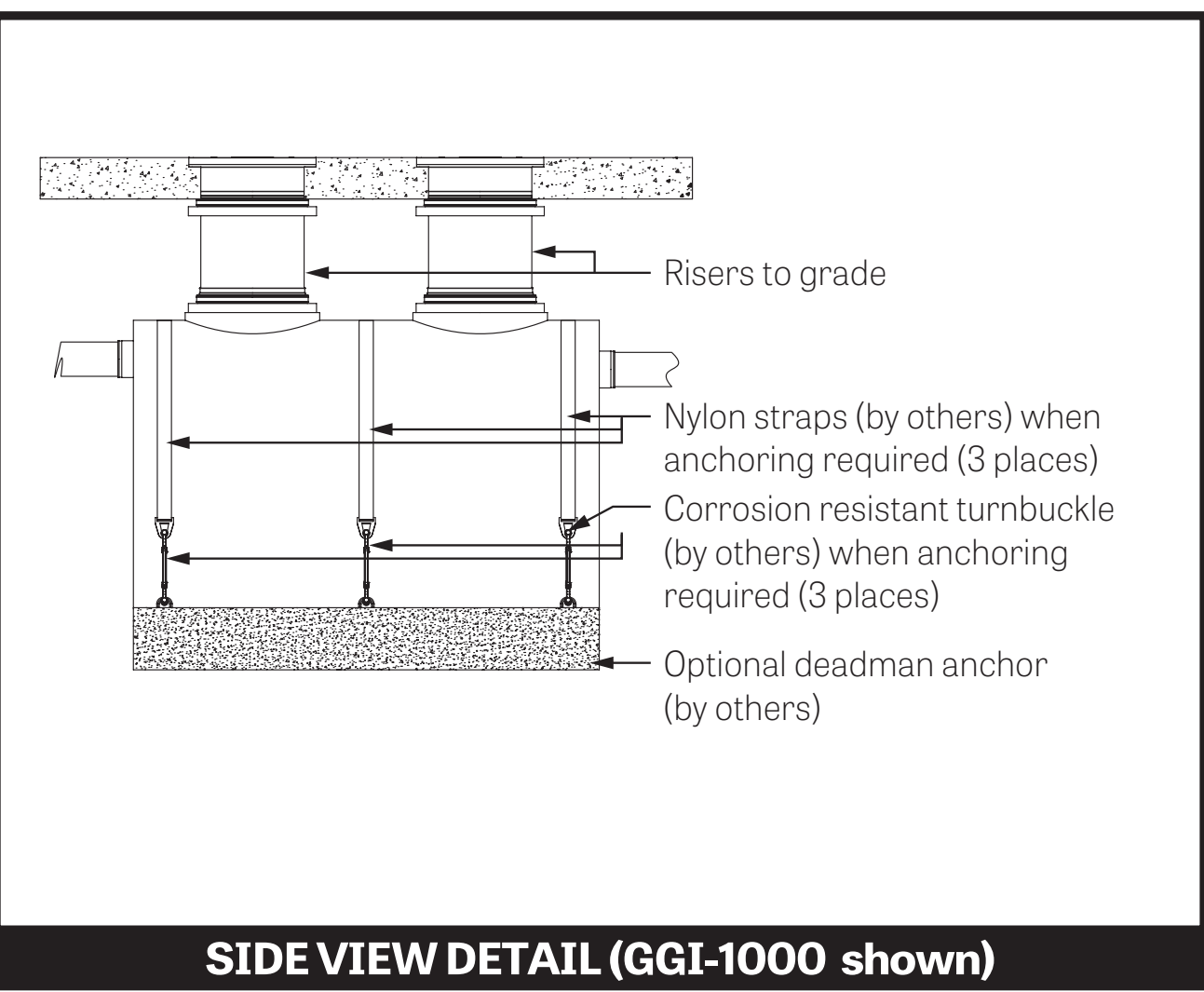
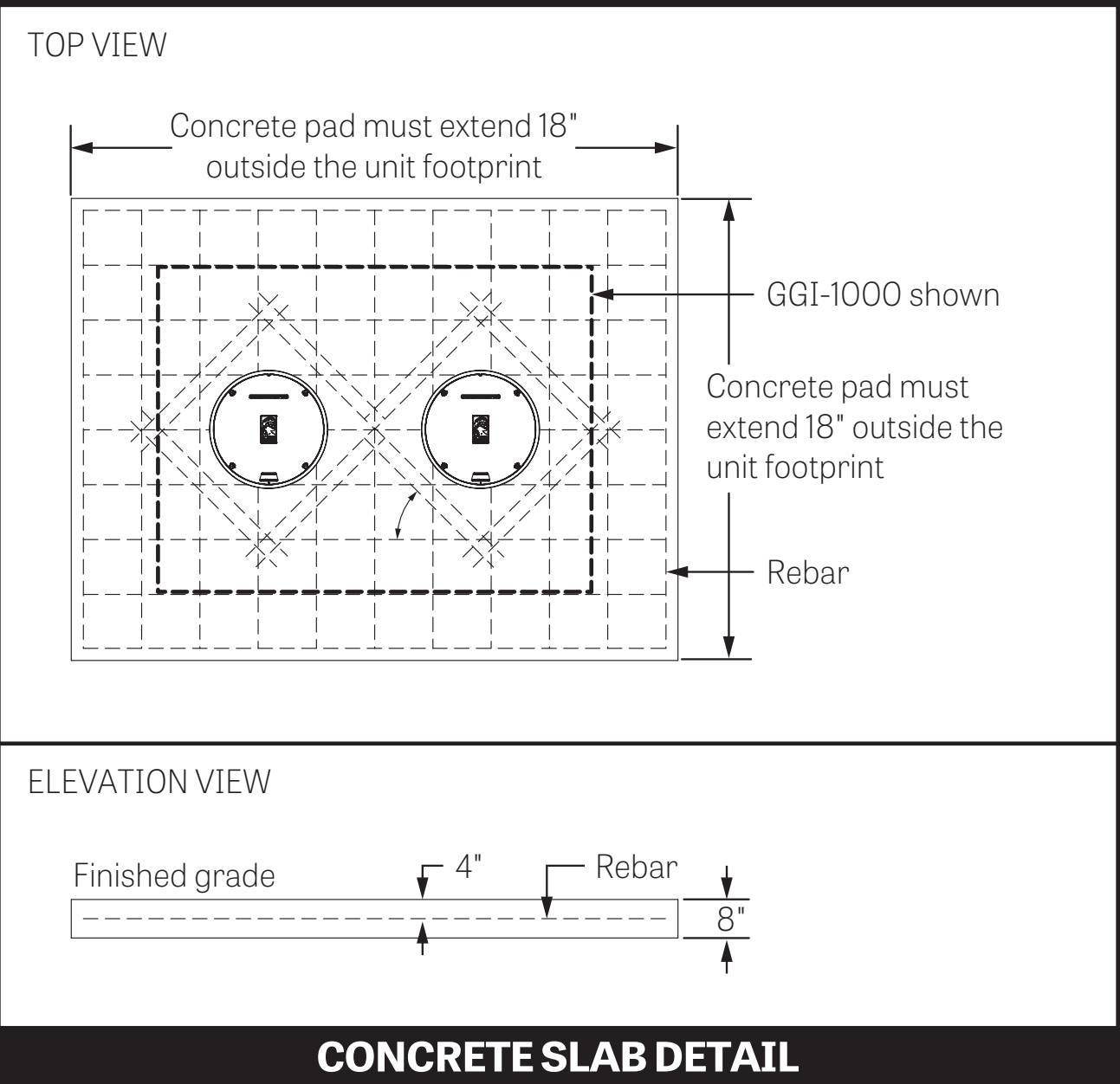
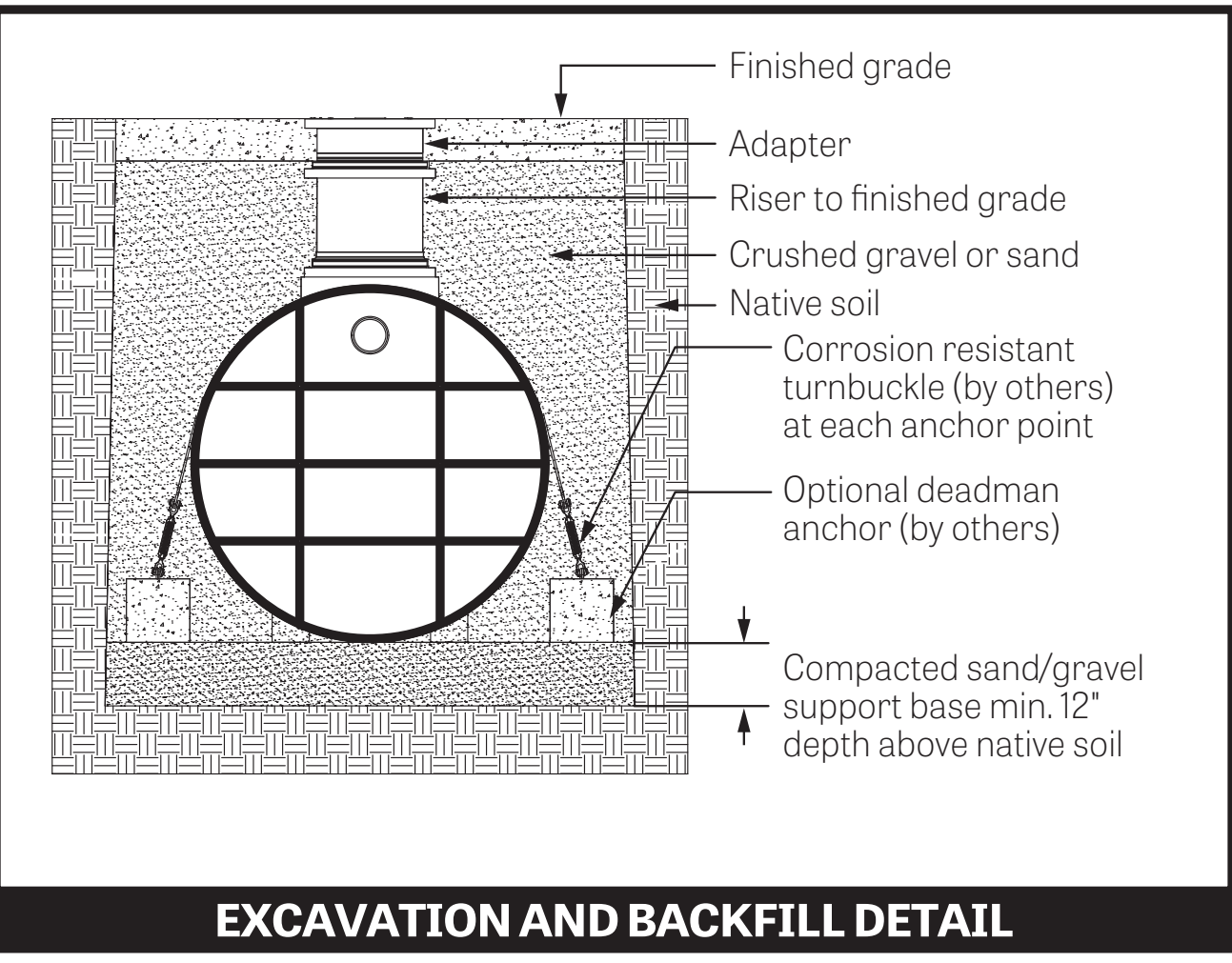
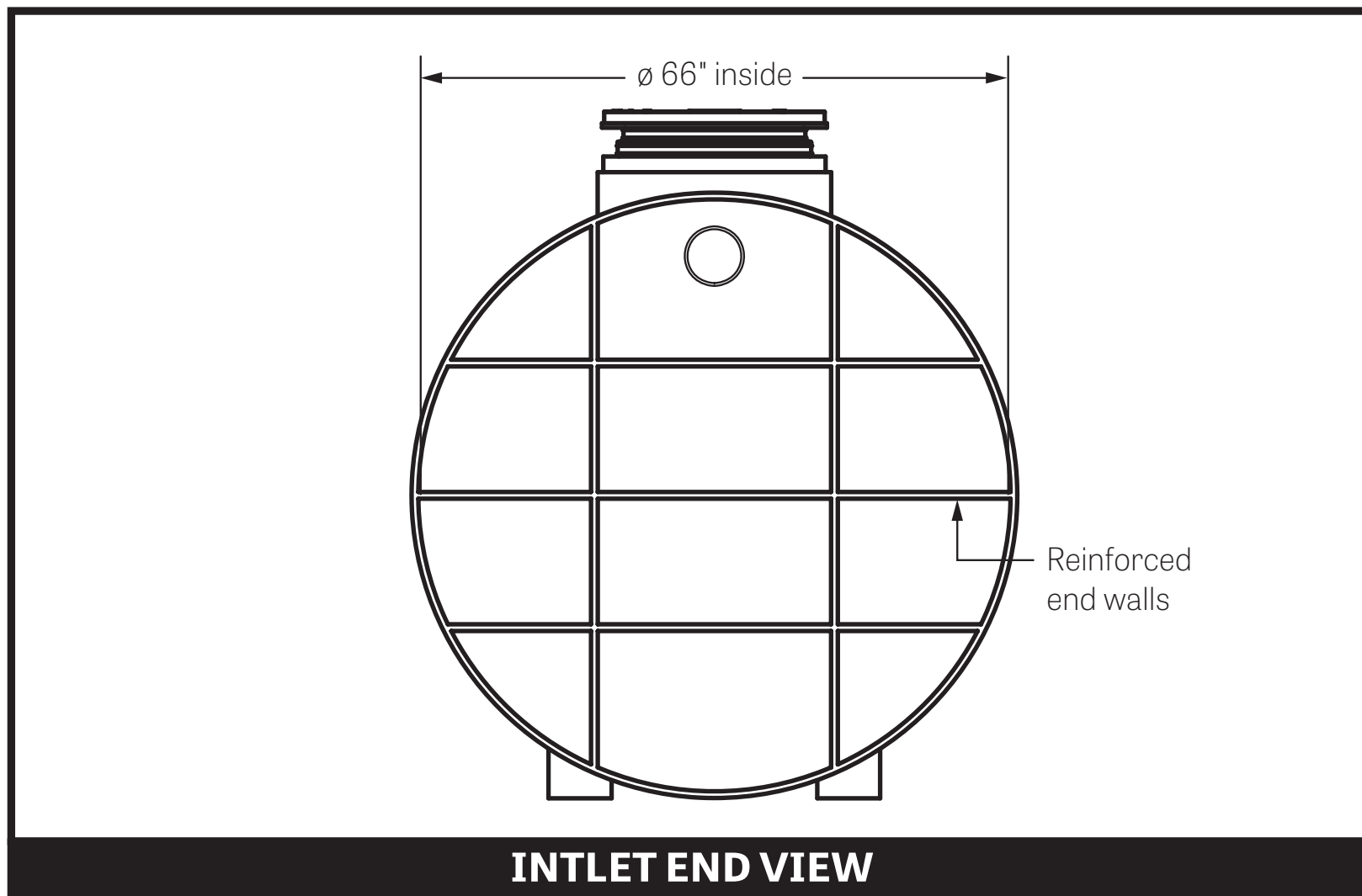
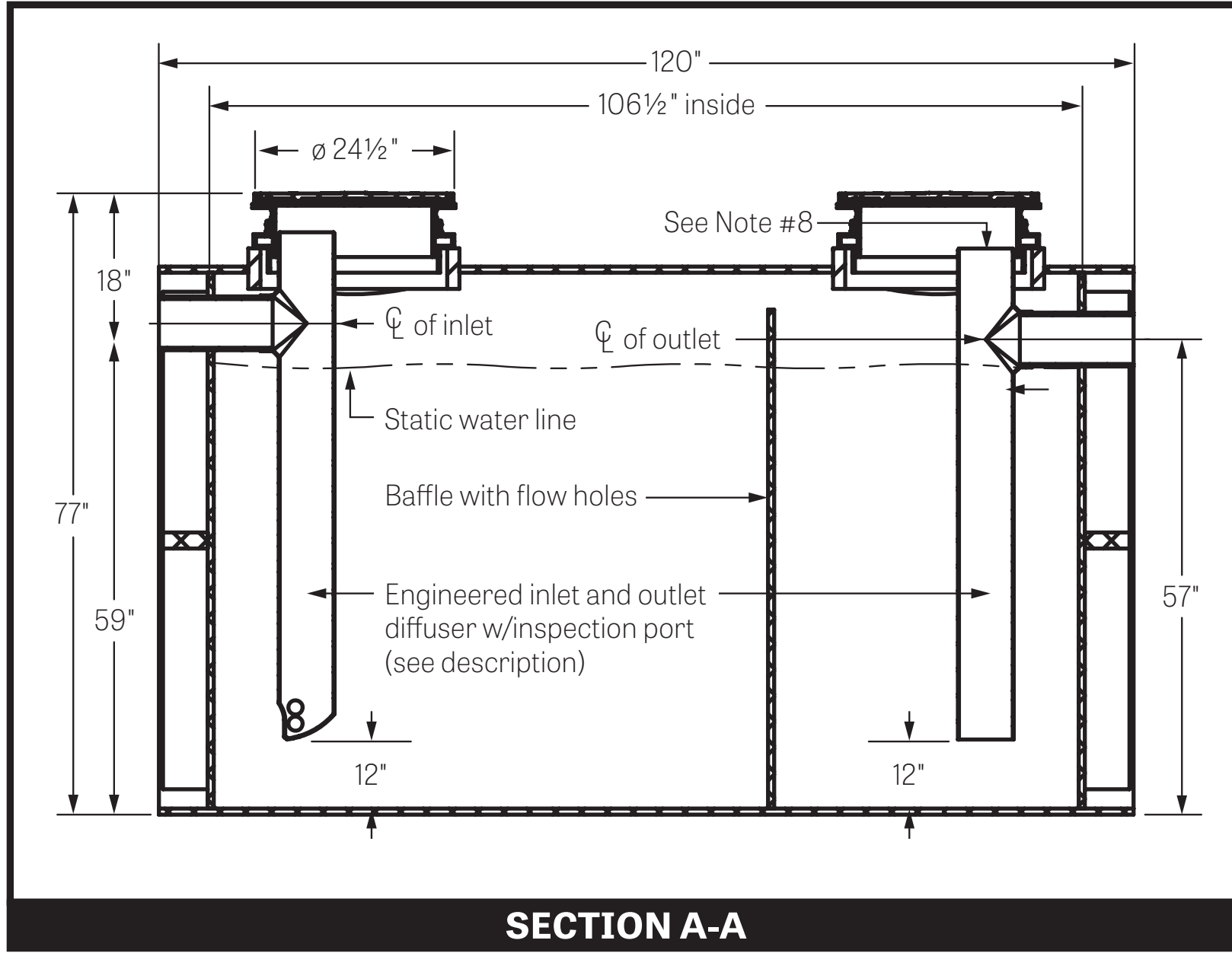
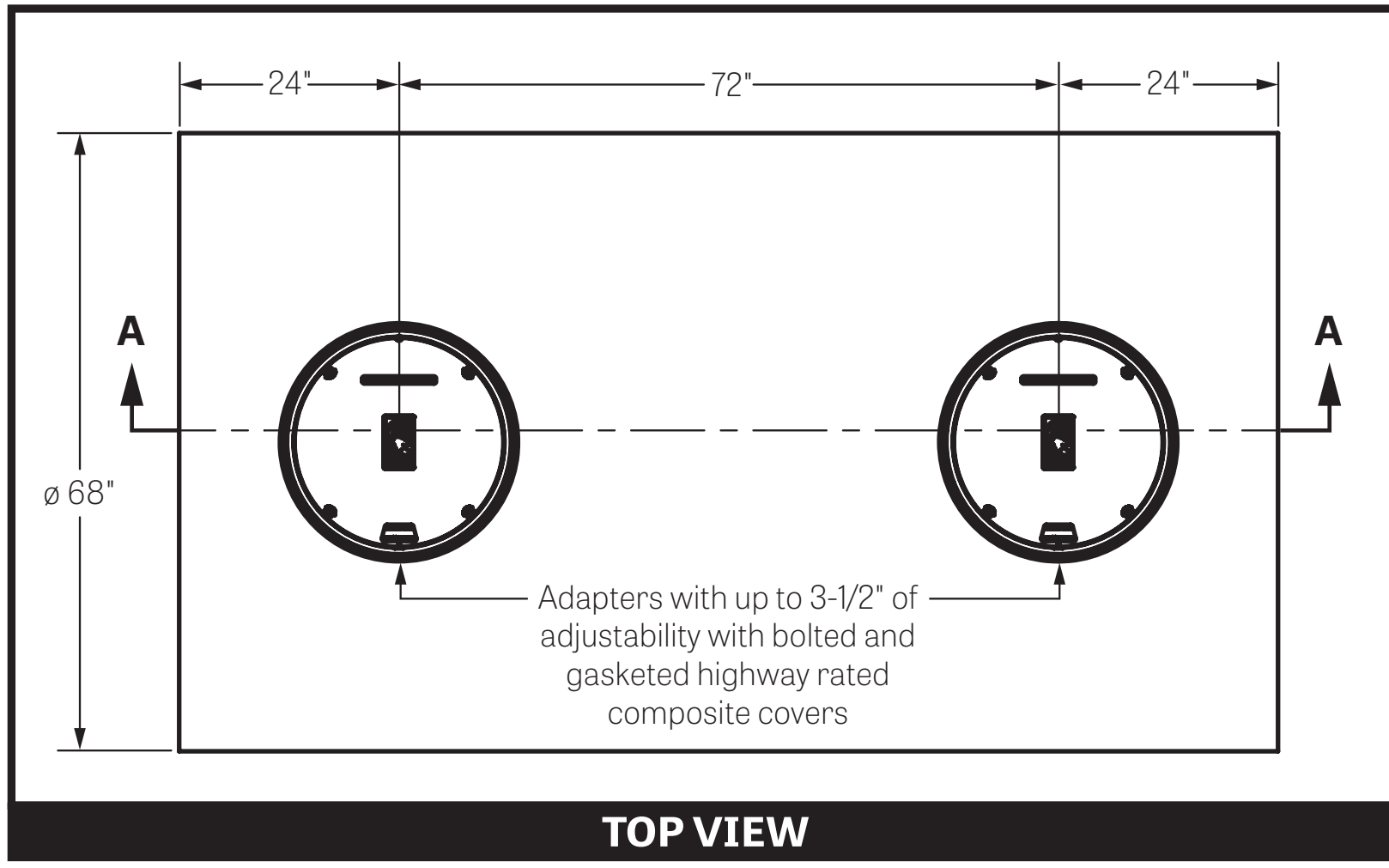

<p>SCHIER LIFETIME GUARANTEED GREASE INTERCEPTORS</p>	<p>9500 Woodend Road Edwardsville, KS 66111 Tel: 913-951-3300 Fax: 913-951-3399 www.schierproducts.com</p>	<p>MODEL NUMBER: GGI-1500-FM6</p>	<p>PART #: 4370-001-04</p>	<p>DESCRIPTION: Polyethylene Gravity Grease Interceptor 314 GPM - 1,500 gallon capacity</p>	<p>DWG BY: B. Karrer</p>
					<p>DATE: 10/13/2017</p>
					<p>REV: 2</p>
					<p>ECO:</p>