



City of Aurora and Fox Metro Water Reclamation District CSO Operational and Maintenance Plan



**Walter E. Deuchler
Associates, Inc.**
CONSULTING ENGINEERS



May 31, 2016
Revision 0

TABLE OF CONTENTS

<u>1.1.</u>	<u>OVERVIEW</u>	1
<u>1.0</u>	<u>Purpose of Plan</u>	1
<u>1.1</u>	<u>Summary of the CSS</u>	2
<u>2.0</u>	<u>BACKGROUND INFORMATION</u>	5
<u>2.1</u>	<u>PCB Order</u>	5
<u>2.2</u>	<u>Sensitive Areas</u>	5
<u>2.3</u>	<u>Pollutant Discharges</u>	5
<u>2.4</u>	<u>Flow Monitoring and System Modeling</u>	6
<u>2.5</u>	<u>Public Notification</u>	8
<u>3.0</u>	<u>PREVENTIVE MAINTENANCE</u>	1
<u>3.1</u>	<u>Street Cleaning / Grit Reduction</u>	1
<u>3.2</u>	<u>Cleaning and Repairs</u>	1
<u>3.3</u>	<u>Chamber Overflow Points</u>	3
<u>3.4</u>	<u>Bar Screen & Backflow Prevention System Cleaning Procedures</u>	3
<u>4.0</u>	<u>INSPECTIONS AND MONITORING</u>	1
<u>4.1</u>	<u>Inspection</u>	1
<u>4.2</u>	<u>Telemetry</u>	1
<u>4.3</u>	<u>Sewer Investigations</u>	2
<u>4.4</u>	<u>Emergency Response</u>	2
<u>5.0</u>	<u>CONTINUOUS EFFORTS AND PROJECTS</u>	1
<u>5.1</u>	<u>CSO Treatment Facilities</u>	1
<u>5.2</u>	<u>CSO Partnership</u>	1
<u>5.3</u>	<u>Wastewater Treatment Plant Improvements</u>	1
<u>5.4</u>	<u>CSO Long Term Control Plans</u>	3

APPENDICES

- Appendix A CSO O&M Plan Checklist
- Appendix B CSO Maps: Overview and Tributary Basin Drawings
- Appendix C Illinois Pollution Control Board Ruling - #PCB 85-224
- Appendix D City of Aurora 2015 Yard Waste Collection Information
- Appendix E CSO Structure Drawings
- Appendix F FMWRD Off-Plant Emergency and Response Plan

1.0 OVERVIEW

1.1 Purpose of Plan

The Combined Sewer System (CSS) in the City of Aurora conveys wastewater and a portion of storm water flow to the Fox Metro Water Reclamation District (FMWRD) wastewater treatment plant for treatment. During certain rainfall events, storm water flow exceeds the containment capacity of the CSS resulting in the discharge of combined wastewater and storm water through several discharge points along the Fox River and Indian Creek. A discharge overflow point is called a “Combined Sewer Overflow” (CSO). The discharge of this combined flow is permitted by the Illinois Environmental Protection Agency (IEPA) through National Pollution Discharge Elimination System (NPDES) permits issued to both the FMWRD (Permit No. IL0020818) and the City of Aurora (Permit No. IL0048518).

The IEPA assigned a Special Condition in the NPDES permit requiring that FMWRD’s previously reviewed and accepted “CSO Operational and Maintenance (O&M) Plan” be reviewed and revised, if needed to reflect system changes. The purpose of the plan is to establish operation, maintenance and inspection procedures to ensure that a CSS and treatment facility will function in a way to maximize treatment of combined sewage. Implementation of the plan will reduce the magnitude, frequency and duration of CSOs by enabling existing facilities to perform as effectively as possible.

The objectives of this CSO O&M Plan are to reduce the total loading of pollutants and floatables entering the receiving stream and to ensure that FMWRD and the City of Aurora work toward and ultimately achieve compliance with water quality standards. This Plan includes mechanisms and specific procedures to meet the following requirements contained in FMWRD’s and the City of Aurora’s NPDES permits:

- Collection system inspection on a scheduled basis.
- Sewer, catch basin and regulator cleaning and maintenance on a scheduled basis.
- Inspections and preventative maintenance on pump/lift stations.
- Collection system replacement, where necessary.
- Detection and elimination of illegal connections.
- Detection, prevention and elimination of dry weather overflows.

- Collection system operation to maximize storage capacity and combined sewer portions of the collection system operation to delay storm entry into the system.
- Treatment and collection systems operation to maximize treatment.

In response to the above mentioned requirements, FMWRD and the City of Aurora have reviewed and revised the following CSO O&M Plan. It should be noted that FMWRD and City of Aurora have frequently performed joint operation and maintenance activities in CSS investigation and rehabilitation programs while conducting their routine inspections, cleaning and repairs independently. Therefore, this plan reflects items and activities from both entities.

The CSO O&M Plan Checklist for FMWRD is included in **Appendix A**.

1.2 Summary of the CSS

Construction of the combined sewer system began in the late 1800's. Today, the CSS encompasses approximately 7,145 acres serviced by approximately 130 miles of combined sewers and is located entirely within the corporate limits of the City of Aurora. Land use within the CSS varies from commercial and light industrial to residential.

There are presently sixteen (16) permitted CSO diversion structures in the City of Aurora's CSS and one (1) permitted CSO diversion structure at the headworks of FMWRD's wastewater treatment plant. **Figure 1** in **Appendix B** depicts the locations of these CSOs within the collection system. The latitude and longitudinal locations of these overflow structures are described in **Table 1**. The City's CSS is served by the Original Combined Sewer Interceptor (OCSI) ranging in size from 36-inches to 69-inches in diameter, which transports dry weather flows and a portion of the wet weather flows to FMWRD's wastewater treatment plant. All permitted CSOs discharge into the Fox River with the exception of one structure that discharges into Indian Creek, which is tributary to the Fox River.

FMWRD owns the CSO diversion structure at the FMWRD wastewater treatment plant, the OCSI, as well as all separated sanitary sewers with a diameter of fifteen inches (15") or greater. The City of Aurora owns the remaining CSO diversion structures, all sewers of the CSS and all separated sanitary sewers less than fifteen inches (15") in diameter. **Figure 2** through **Figure 18** in **Appendix B** also includes maps of the tributary basins adjacent to each overflow.

TABLE 1. PHYSICAL LOCATION OF OVERFLOW STRUCTURES

Discharge No.	Discharge Name	LOCATION OF DISCHARGE	
		Latitude	Longitude
004	HAZEL	41° 44' 32"	88° 19' 38"
001	RATHBONE	41° 44' 38"	88° 19' 51"
005	THIRD	41° 44' 53"	88° 19' 38"
010	FIRST	41° 45' 47"	88° 19' 32"
015	WEST BENTON	41° 45' 23"	88° 19' 05"
018	WEST GALENA	41° 45' 32"	88° 18' 56"
021	ELM (WEST PARK)	41° 45' 38"	88° 18' 50"
022	SUPERIOR	41° 46' 00"	88° 18' 32"
023	WEST ILLINOIS	41° 46' 14"	88° 18' 38"
002	EAST ILLINOIS	41° 46' 14"	88° 18' 26"
025	TRASK-DEARBORN	41° 46' 07"	88° 16' 19"
017	STOLP	41° 45' 27"	88° 18' 58"
008	EAST BENTON	41° 45' 22"	88° 19' 01"
003A	PIERCE	41° 46' 00"	88° 18' 29"
027	TREATED CSO OUTFALL	41° 45' 55"	88° 18' 30"
16A	CLARK	41° 45' 15"	88° 19' 05"
002	FMWRD WWTP	41° 43' 00"	88° 20' 58"

The City owns and FMWRD operates a CSO treatment facility located on the east bank of the Fox River, north of downtown on Route 25. This facility collects and treats the CSOs from four of the CSO structures (CSO #002, 003A, 022, and 025). At lower level storm events, the facility stores and later releases the flows back into the OCSI for delivery to the

waste water treatment plant. When the capacity of the storage tanks is reached, the excess flow undergoes primary clarification and disinfection prior to discharging into the Fox River through CSO #027. As part of the NPDES permit, discharges are analyzed for BOD, TSS, fecal coliform, pH and temperature. The overflow system is automated and monitored by FMWRD's SCADA system.

2.0 BACKGROUND INFORMATION

2.1 PCB Order

The Illinois Pollution Control Board (PCB) issued order (PCB 85-224) which authorized the CSO discharges from FMWRD's and the City of Aurora's CSS and CSOs in accordance with 35 Ill. Adm. Code 306.305 and 301.361(a). The original order is dated July 13, 1988 and an amended order is dated June 21, 1990. A copy of both orders is included in **Appendix C**.

2.2 Sensitive Areas

As part of the CSO LTCP's for each entity, a sensitive area assessment was conducted. The FMWRD LTCP concluded that CSO 002 at FMWRD's waste water treatment plant (WWTP) does not discharge to a sensitive area. Within the City of Aurora, the IEPA has deemed that CSO #001 (Rathbone), CSO #022 (Superior), and CSO #023 (West Illinois) discharge into sensitive areas due to their respective proximities to parks. All other CSOs were determined not to discharge to a sensitive area in the City of Aurora LTCP.

2.3 Pollutant Discharges

As a result of the various sewer separation projects and other improvements that FMWRD and the City of Aurora have undertaken, CSO discharges during rain events have been drastically reduced. CSO locations are checked on a regular weekly schedule by both FMWRD and City of Aurora personnel to clean those structures with bar screens and to identify any dry weather events as soon as possible for correction.

The Interceptors along the Fox River are monitored and cleaned on an as-needed basis, keeping the storage capacity of the line at or near its maximum.

Flows into the main treatment plant pass through a bar screen building, which automatically cleans the screens for later dumpster disposal. The FMWRD CSO is located at the bar screen inflow channel, before the bar screen, with a manually cleaned bar screen on the CSO outlet pipe. All CSO flows are designed to pass through screening before going to the river to minimize the amount of solids potentially discharged into the Fox River. The treatment plant has recently adjusted and set the overflow weir elevation at the

most optimum elevation to maximize the flow through the bar screens and the grit tanks and to minimize the overflow potential. This work was completed as part of the FMWRD CSO LTCP Phase 1 compliance. See Section 5.3 for further information about the Phase 1 FMWRD CSO LTCP work.

2.4 Flow Monitoring and System Modeling

For FMWRD, the overflow at the WWTP is monitored by the SCADA system. The SCADA system monitors flow and duration of each CSO event. See Section 4.2 for more information about FMWRD's SCADA system.

FMWRD and the City of Aurora jointly own rain gauges and 60 Teledyne ISCO 2150 flow meters. Flow meters are installed at each of the permitted CSO diversion structures to record the frequency and duration of overflow events. The remaining flow meters are periodically relocated throughout the CSS and separated sanitary sewer system to monitor wet weather flow conditions and assist in identifying and quantifying infiltration and inflow. Data from the flow meters is downloaded twice a month and analyzed for any irregularities in the operation of the system. A summary table of the City of Aurora's CSO Structure and Flow Meter location is included as **Table 2**.

CSO events are reported monthly to the IEPA as part of each agency's Discharge Monitoring Reports (DMRs) in accordance with their respective NPDES permits.

Table 2. Summary of Overflow Information (updated 04/16)

<u>Overflow No.</u>	<u>CSO Name</u>	<u>FLOWMETER Condition</u>	<u>Overflow Threshold (Inches)</u>	<u>Disch. Pipe Size (“)</u>
<u>AURORA</u>				
CSO No. 001	Rathbone	Dry	Any Flow*	Top of Dam
CSO No. 002	E. Illinois	Dry	45.75	36
CSO No. 003A	Pierce	Dry	69.38	48
CSO No. 004	Hazel	Wet	52.5	Inside Bar Screen Chamber
CSO No. 005	Third	Dry	39.6	20
CSO No. 008	E. Benton	Wet	43	72
CSO No. 010	Prairie & River (First)	Dry	Any Flow**	24
CSO No. 015	W. Benton	Wet	39.36	35 to 42
CSO No. 016A	Clark	--	***	-
CSO No. 017	Stolp	Wet	1.10 mgd****	16.5
CSO No. 018	W. Galena	Dry	Any Flow**	18
CSO No. 021	West Park	Dry	Any Flow**	27
CSO No. 022	Superior	Dry	38.64	48
CSO No. 023	W. Illinois	Wet	26.00	27
CSO No. 025	Dearborn-Trask	Wet	24.13	18
CSO No. 027	CSO Facility	Dry	Any Flow**	36
<u>FMWRD</u>				
CSO No. 002	WWTP	Dry	Any Flow**	72

* Any flow is an indication of an overflow event since the sensor is mounted on the diversion dam

** Any flow is an indication of an overflow event since the sensor is mounted downstream of the diversion structure.

*** No Flowmeter Installed. Emergency overflow for Lift Station

**** Based on field work and hydraulic analysis.

2.5 Public Notification

FMWRD and the City of Aurora have each implemented a CSO Public Notification Plan. The specifics of this program are detailed in a separate report entitled “City of Aurora and Fox Metro Water Reclamation District CSO Public Notification Program”. Fox Metro posts their Discharge Monitoring Reports (DMRs) on their website at <http://www.foxmetro.dst.il.us/cso/>

The City of Aurora posts their Discharge Monitoring Reports (DMRs) on their website at https://www.aurora-il.org/engineering/discharge_monitoring.php.

3.0 PREVENTIVE MAINTENANCE

3.1 Street Cleaning / Grit Reduction

The City of Aurora's maintenance program also includes routine street sweeping. The City of Aurora owns and operates mechanical brooms and vacuum assisted brooms. Streets are typically swept according to the following schedule:

- Downtown streets: 5 nights per week
- Major roads outside the downtown area: 1 time per month
- Residential streets: 1 time every 2 months.

The mechanical brooms are used 100% of the time in the downtown area in order to ensure more effective removal of leaves, paper, and other lightweight wastes.

The City of Aurora also conducts yard waste removal services throughout the year. Leaf removal, general yard waste, and bundled brush collection occurs at various intervals from April through December. The City of Aurora's specific program details and an example schedule from fall 2015 is included in **Appendix D**.

Grit reduction is provided through street cleaning, sewer cleaning, and catch basin cleaning/repairs. Sewer cleaning and catch basin cleaning/repairs is discussed in Section 3.2 below. These are performed on an as-needed basis as required by routine inspections or street flooding.

Further information on the street sweeping, grit reduction, and other pollution prevention measures are discussed in the City of Aurora and FMWRD Pollution Prevention Plan.

3.2 Cleaning and Repairs

FMWRD and the City of Aurora perform in-house cleaning of both sanitary and combined sewer systems in addition to yearly subcontracted work.

FMWRD's subcontractor televises and cleans approximately 125,000 linear feet of sewer lines per year on a rotating basis so that the entire collection system is televised and cleaned in an approximately 7-year period. In addition, FMWRD has spent an average of \$50,000 per year on subcontractors for cleaning of sewer interceptors or siphon tubes larger than fifteen inches (15") in diameter. This cleaning also consists of high pressure water jetting along with vacuum suction cleaning as well as power bucketing (specially designed,

machine-driven buckets and scrapers that are specifically sized for the pipe being cleaned).

Additionally, Fox Metro's crews flush and clean an additional approximately 50,000 feet of sewers, interceptors and siphon tubes up to fifteen inches (15") in diameter on a yearly basis. Their in-house sewer cleaning is conducted at problem areas determined by televising efforts or generally at the mid-point of the subcontractor's most recent cleaning. This results in each interceptor segment being cleaned once every three years. Sewer cleaning consists primarily of high pressure water jetting along with vacuum suction cleaning to remove silt and debris with Vac-jet trucks. FMWRD utilizes CASSWORKS, a computer database program for tracking maintenance tasks and schedules. The entirety of FMWRD's assets (sewer lines, interceptors, pump stations, forcemains, manhole structures, and equipment) has been entered into the CASSWORKS system. The CASSWORKS system is used to generate preventative maintenance task orders and repair work orders, which are distributed to maintenance staff. Once the orders are complete, the details, notes, and follow-up reports are entered back into the CASSWORKS system for logging purposes. Various tasks are programmed to repeat on the needed frequency (monthly, biannually, annually, etc.). The CASSWORKS system is utilized for the entire FMWRD collection system, not just the CSO areas.

In 2009, the OCSI was inspected using a robotic system. This robotic system utilized multi-sensors of closed circuit television, sonar, hydrogen sulfide gas and temperature, and laser sensors to collect data on debris quantity, pipe corrosion levels, and pipe condition to assist FMWRD prioritize areas for O&M activities. Considerable efforts are being made by FMWRD to remove accumulation of grit and debris from the OCSI located along the Fox River to maximize the interceptor's transport capacity.

The City of Aurora's Water and Sewer Maintenance Division cleans approximately 110,000 feet of sanitary sewers per year with in-house staff and equipment.

As part of their systematic maintenance programs, FMWRD and the City of Aurora perform in-house sewer repairs and manhole sealing. FMWRD's 2015-2016 fiscal year budget includes \$452,490 for manhole rehabilitation, replacement, sewer grouting, and sewer sealing.

The Water and Sewer Maintenance Division cleans, replaces or repairs approximately 400 catch basins each year, beyond those which require cleaning.

3.3 Chamber Overflow Points

The CSO Operational Plan Checklist and Certification Form questions if the “stop planks are the highest level practical without causing basement backups or excessive street flooding”. None of the FMWRD or City of Aurora CSO diversion structures have stop planks per se. The overflow points in the CSO chambers are split between fixed dams (brick & mortar, etc.), adjustable weir plates, and ‘high’ set overflow pipes. Over the years, some adjustments have been made on the fixed dams themselves, with most of the efforts focused on reducing overflows and backups on the upstream sewers and connections. A specific drawing of each overflow chamber is included in **Appendix E**.

3.4 Bar Screen & Backflow Prevention System Cleaning Procedures

The various bar screens are typically checked and cleaned on a regular weekly schedule, where personnel remove the debris from the bar screens and dispose of it in a dumpster. No special storm event cleaning is done unless a problem is observed and FMWRD or the City of Aurora is notified.

Several of the City of Aurora CSO structures have backflow prevention devices installed on the outfall pipes to prevent the flood waters from flowing back into the CSS. These backflow prevention devices have been very effective in protecting the CSS and maximizing flow to the WWTP. **Table 3** identifies the CSOs that have backflow prevention devices and the type of device at each: flexible flapgate, “Tide-Flex Checkmate” valve, or “Tide-Flex Duckbill” valve. Backflow prevention devices are inspected on a weekly basis. As of November 2015, all backflow prevention devices that were scheduled to be installed in the City of Aurora’s LTCP have been installed.

TABLE 3. BACKFLOW PREVENTION DEVICES

Discharge Number	Discharge Name	Type of Backflow Prevention Device
005	THIRD	TideFlex Checkmate
008	E. BENTON	TideFlex Checkmate
016A	CLARK	TideFlex Duckbill
017	STOLP	TideFlex Duckbill
022	SUPERIOR	Flexible Flapgate
003A	PIERCE	Tideflex Checkmate
002 (Aurora)	E. ILLINOIS	Tideflex Duckbill

4.0 INSPECTIONS AND MONITORING

4.1 Inspection

FMWRD's crews independently perform inspections throughout the CSS on their overflow structures, outfalls, bar screens and siphon tubes on a weekly basis with follow-up inspections are conducted on an as needed basis. This inspection policy ensures that if dry weather overflows occur accidentally, they are reported and fixed immediately. In addition, combined sewer flow entering the wastewater treatment plant is monitored by FMWRD to determine if wet weather flow is discharged from FMWRD's CSO outfall at the headworks of the treatment facility.

Waste water lift stations and bar screen facilities owned by FMWRD are maintained and inspected by a crew on a weekly basis. As part of the inspections, motor amperage readings, flow monitoring, and pump checks are made to determine that the pumps are working properly.

Lift stations owned by the City are typically inspected three times per week.

4.2 Telemetry

Both FMWRD and the City of Aurora administer separate telemetry response programs in conjunction with 24-hour response crews.

FMWRD monitors the District owned remote lift stations and bar screen facilities as well as the City of Aurora owned CSO Treatment Facility with a Supervisory Control and Data Acquisition (SCADA) system using a designated (licensed) radio frequency. This system offers a wide monitoring range of lift station equipment, history and trending capabilities, off-site control capabilities and the ability for monitoring real time measurements for viewing the status of the entire wastewater collection system. Information obtained from the SCADA system has resulted in improved maintenance of the remote lift stations as well as faster, more efficient responses to emergency situations.

FMWRD updated their plant wide telemetry system with a new SCADA system using a fiber optic network in 2009. The new system provides real time (15-second interval refresh) instrumentation information, history and trending capabilities and remote/off-site control capabilities of numerous wastewater processes, and equipment for the full

maximization of the wastewater treatment plant.

4.3 Sewer Investigations

FMWRD and the City of Aurora have undertaken numerous sewer investigations over the years, both jointly and independently. Sewer investigations typically consist of smoke testing, dye water testing, sewer televising, manhole inspections and flow monitoring. These investigations have focused on identifying sources of inflow and infiltration, as well as locating structural defects in the wastewater collection system. Following the investigations, sewer rehabilitation, replacement and/or sewer separation projects are identified. Once the projects are identified, the work is then budgeted and constructed accordingly.

4.4 Emergency Response

FMWRD's Field Operations Department and the City of Aurora's Water and Sewer Maintenance Division receive numerous phone calls from residents requiring emergency assistance. FMWRD has an "Off Plant Emergency and Response Plan", last updated in May 2015, that addresses emergency response procedures, including basement backups. The Off Plant Emergency and Response Plan is included in **Appendix F**. All calls FMWRD receives within the CSS are forwarded to the City of Aurora. City of Aurora crews respond to the majority of the calls, which include reports of street flooding, basement flooding, basement sewer backups, sewer odors, clogged sewers, and water main related leaks. Rectifying problems is a key component of both the City of Aurora's and FMWRD's operational and maintenance program since minor repairs usually prevent the onset of greater problems.

The City logs all of their response actions on a computer database and the information can be easily retrieved and reviewed. Accordingly, FMWRD logs and records the same information in CASSWORKS.

5.0 CONTINUOUS EFFORTS AND PROJECTS

5.1 CSO Treatment Facilities

The City of Aurora, in conjunction with FMWRD, constructed a primary CSO Treatment Facility in 1997. The facility is located on the East bank of the Fox River on Broadway Avenue (IL Route 25) immediately north of the downtown area. The CSO Treatment facility is owned by the City of Aurora and operated/maintained by FMWRD. The facility is designed to treat and disinfect combined sewer flow from four (4) CSOs (#002, 003A, 022 and 025) prior to discharging the treated effluent into the Fox River. This facility also has the potential to treat combined sewer flow from two (2) additional CSOs (#021 and 023) as well.

Construction of a Wet Weather Treatment Facility (“Building T”) at FMWRD’s WWTP site was completed in 2012. See Section 5.3 for further discussion of Building T.

A City of Aurora treatment facility is planned for future construction in the vicinity of Rathbone Avenue (CSO #001). The City of Aurora is presently in the process of purchasing property to build the proposed CSO treatment facility, which will treat excess flows from CSOs #001 and 004.

5.2 CSO Partnership

FMWRD and the City of Aurora have established a partnership for the continuous improvement of the CSS and its tributary areas. This partnership is not only characterized by the maintenance and rehabilitation efforts summarized earlier, but is also characterized by their commitment to meeting regularly to discuss CSO issues that affect both entities. Representatives from both entities meet monthly to discuss and coordinate construction projects, sewer investigations, and environmental issues related to the CSS as well as their various requirements in their respective NPDES permits.

5.3 Wastewater Treatment Plant Improvements

In 2005, FMWRD completed a 20-year Master Plan for the purpose of evaluating existing conditions and forecasting the twenty year needs of the collection system and the wastewater treatment plant. Shortly thereafter, FMWRD began implementation of Phase 1

of the Master Plan, which upgraded the existing wastewater treatment for the following purposes:

- Reduce peak hour hydraulic loading to the existing WWTP and provide treatment for excess peak combined sewer flows,
- Reduce untreated CSO events at the WWTP, and
- Improve solids handling to reduce the volume of sludge produced.

The Phase 1 Improvements were considered an upgrade to the existing WWTP and did not alter the design average flow (DAF) or design maximum flow (DMF) rating in FMWRD's current NPDES permit.

As described in the Master Plan, the key element to reducing the frequency of CSOs to the Fox River is to reduce the amount of rain induced inflow from the incoming WWTP flow. Reduction of rain induced inflow will be accomplished in the following two ways:

- 1.) Direct removal of flow from the interceptors will be accomplished by constructing two (2) excess flow facilities within the collection system as described in the "Wet-Weather Facilities Study" as Prepared by WEDA in 2005. These facilities will capture the rain induced peak flow from the interceptors, retain the flow and then slowly release the flow back into the interceptors after the rain event has subsided and interceptor flow has decreased. The two excess flow facilities will be constructed in the future along the Waubonsie Interceptor and the North Aurora Interceptor. The 2025 peak flow to the WWTP accounts for attenuating peak flows by the two future excess flow facilities.
- 2.) Treatment of excess flow at the WWTP site is accomplished by a Wet Weather Treatment Facility (Building T). Completed in 2012, the facility is located at the northern most end of the existing WWTP. Below is a simple block diagram of the treatment processes as outlined in the 2005 Master Plan. An additional 54 mgd of flow in excess of 85 MGD (DMF) receives a minimum of primary treatment and disinfection. The operators of the WWTO also have the ability to direct the effluent from the Wet Weather Facility to tertiary filtration.

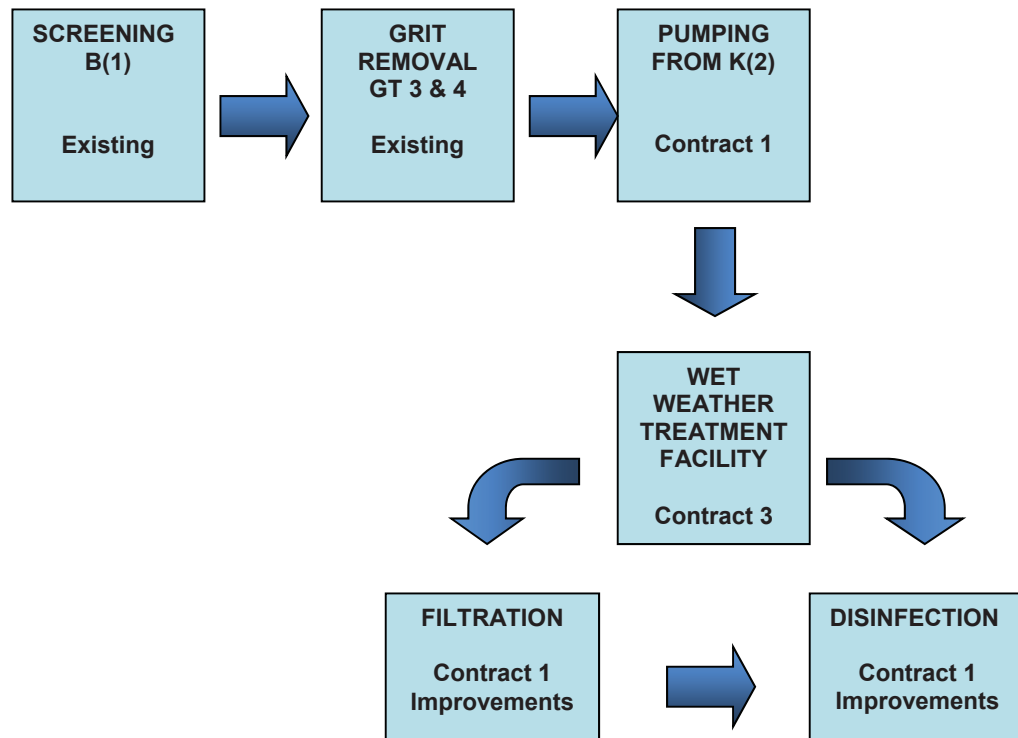

The Wet Weather Treatment Facility required a new K(2) Pump Station to convey the wet weather flows. This pump station was constructed under the Contract 1 project in 2010. The Contract 1 project also included the expansion of the chlorine contact tanks, the installation of a force main piping to convey the sewage from the K(2) Pump Station to the Wet Weather Treatment Facility, and a gravity sewer to convey the Wet Weather Treatment Facility’s effluent to the tertiary filters and/or chlorine contact tanks.

The design and construction of the Wet Weather Treatment Facility is referred to as Contract 3 and was identified as part of the Phase 1 Improvements outlined in the 2005 Master Plan. Contract 3 also included a recovery pump station, which is located at the Wet Weather Treatment Facility to pump stored wet weather flows back into the North Aurora Interceptor upstream of the WWTP head works.

5.4 CSO Long Term Control Plans

Per a Special Condition in the NPDES permits for both FMWRD and the City of Aurora, both agencies have prepared CSO Long Term Control Plans (LTCP) for assuring that the discharges from the CSO outfalls comply with all applicable federal and state regulations and standards, including applicable water quality standards.

Both agencies developed their LTCPs utilizing the Presumptive Approach as outlined

below. The Presumptive Approach requires reducing the CSOs to meet one of three criteria as described below. By meeting one of these three criteria there is presumed to be an adequate level of control to meet applicable state and local WQS in the receiving stream.

The three criteria are listed below:

1. *“No more than an average of four overflow events per year, provided that the permitting authority may allow up to two additional overflow events per year. For the purpose of this criterion, an overflow event is one or more overflows from a combined sewer system as a result of a precipitation event that does not receive the minimum treatment specified.”*
2. *“The elimination or the capture for treatment of no less than 85% by volume of the combined sewage collected in the combined sewer system during precipitation events on a system-wide annual average basis.”*
3. *“The elimination or removal of no less than the mass of the pollutants, identified as causing water quality impairment through the sewer system characterization, monitoring, and modeling effort, for the volumes which would be eliminated or captured for treatment under paragraph 2 above.” (EPA, 1994).*

The Demonstrative Approach requires a demonstration that a selected control program, though not meeting the criteria described in the presumption approach described above, is adequate to meet the water quality-based requirements of the CWA. With this approach, there are no specific limits on CSO events, in regard to flow or pollutant loading. To be a successful control program, each of the following must be demonstrated:

1. *The planned control program is adequate to meet the WQS and protect the designated uses, unless WQS or uses cannot be met as a result of natural background conditions or pollution sources other than CSOs,*
2. *The CSO discharges remaining after implementation of the planned control program will not preclude the attainment of WQS or the receiving water’s designated uses or contribute to their impairment. Where WQS and designated uses are not met in part because of natural background conditions or pollution sources other than CSOs, a total maximum daily load, including a waste load*

allocation and a load allocation, or other means should be used to apportion pollutant loads,

3. *The planned control program will provide the maximum pollution reduction benefits reasonably attainable, and*
4. *The planned control program is designed to allow cost effective retrofitting if additional controls are subsequently determined to be necessary to meet WQS or designated uses.*

The demonstrative approach requires that CSO discharges that remain after LTCP implementation will meet the Water Quality Standards (WQS) for that body of water.

Submitted to the Illinois Environmental Protection Agency (IEPA) on March 31, 2010 and approved by the IEPA on July 31, 2014, FMWRD's LTCP adopted the "Presumptive Approach" as outlined in the 1994 CSO Control Policy. During extreme wet weather conditions where flows exceed the combined capacity of the WWTP and the Wet Weather Treatment Plant (flows in excess of 139 MGD), the flow is diverted directly into the Fox River prior to the headworks from CSO Outfall 002. The overflow weir is located prior to screening and grit removal and receives no treatment prior to discharge. Construction activities include improvements to the existing North wastewater treatment facility, construction of a new South wastewater treatment facility, and construction of flow equalization basins along the Waubonsie Interceptor and the North Aurora Interceptor. Phase 2 of the LTCP will be completed by December 31, 2019.

The City of Aurora's LTCP was submitted in March 2010 and revised in April 2011. The City of Aurora's plan includes:

- Expanding the capacity of the combined sewer system with sewer separation projects via installation of new storm sewers.
- Modifying existing overflow structures to maximize the flow to FMWRD's WWTP with the backflow prevention devices.
- New permanent flow meters at CSO #001 Rathbone Avenue and other locations, as appropriate.
- Implementation of green infrastructure to remove stormwater from the system.

- Construction of a new CSO treatment facility near Rathbone Avenue.
- Construction of a pump station near Hazel Avenue.

Both entities are implementing and completing projects according to their proposed LTCP schedules. Below is a summary of the various completed and in-progress projects for each entity, most of which also fulfill each entity's Long Term Control Plan requirements.

FMWRD Completed Projects – Phase 1

<u>Phase 1</u>	<u>Capital Costs</u>
TPAD	\$18,130,000
Contracts 1 & 2	\$19,877,000
Contract 3	\$11,845,000
Land Procurement for F.E.B.s	\$ 2,000,000
Tertiary Filter Improvements (Filters 1-7)	<u>\$ 7,000,000</u>
TOTAL	\$58,852,000±

FMWRD Projects in Progress – Phase 2

Waubonsie Interceptor River Crossing

- Design complete
- Bids received in September 2015
- IEPA loan approval received in November 2015
- Bid awarded at \$5,426,942
- Notice to proceed in December 2015
- Construction scheduled to be completed in April 2017

South Wastewater Treatment Facility Improvements

- Design complete
- Bids received in September 2015
- IEPA loan approval received in November 2015
- Bid awarded at \$87,927,000
- Notice to proceed in December 2015
- Construction scheduled to be completed in December 2018

Tertiary Filter Improvements (Filters 8 and 9)

- Design complete
- Construction underway on Filter 8
- Anticipated completion of Filter 8 in Spring 2016
- Filter 9 improvements scheduled for 2017
- Estimated project cost of \$2,200,000

North Wastewater Treatment Facility Improvements

- Currently in design stage
- Construction to begin in November 2017
- Construction to be completed in October 2018
- Estimated project cost of \$6,800,000

TOTAL **\$102,354,000±**

City of Aurora Completed Projects

	<u>Expenditure through 2015</u>
<u>2011 LTCP Funding Mechanism</u>	\$396,000
<u>2012 CSO 025 Improvements</u>	\$1,199,125
<u>CSO Diversion Structure Modifications</u>	\$361,710
<u>Remote Metering and Telemetry</u>	\$15,000
<u>Sewer Separation Projects</u>	
CSO 001: 2012 Storm Sewer Extensions	\$140,100
CSO 001: 2015 Charles Harrison Storm Sewer	\$1,113,218
CSO 004: 2009 North Avenue Phase 2	\$2,100,000
CSO 004: 2010 South Avenue Storm Sewer	\$245,488
CSO 004: 2012 Storm Sewer Extensions	\$319,800
CSO 004: 2013 Storm Sewer Extensions	\$389,000
CSO 004: 2014 Fourth Street Storm Sewer	\$477,620
CSO 008: 2010 Spring Street Sub Basin	\$5,140,000
CSO 008: 2010 Basin 6 – Fulton/Fenton/Smith	\$1,702,000
CSO 008: 2015 Galena-New York Separation	\$4,489,000
CSO 010: 2015 Woodlawn, Prairie, Highland Storm	\$2,393,148
CSO 015: 2009 Basin 13 River St. Sub Basin	\$3,494,000
CSO 015: 2010 Basin 13 Phase 2	\$327,000
CSO 015: 2010 Basin 13 Phase 3	\$2,387,000
CSO 015: 2015 Lake Street Sewer Separation	\$1,300,000
CSO 022: 2013 Northeast Sewer Separation	\$2,994,231
<u>Green Infrastructure Projects</u>	\$1,985,470

TOTAL **\$31,008,485±**

City of Aurora Projects in Process

	<u>2016-2022 Proposed Expenditure</u>
<u>CSO Diversion Structure Modifications</u>	\$4,650,000
<u>Remote Metering and Telemetry</u>	\$985,000
<u>Property Acquisition for CSO Storage Facility</u>	\$500,000

Sewer Separation Projects

CSO 008: 2016 Galena Downer Separation	\$7,365,000
2017-2022 Upcoming Projects TBD	\$5,000,000

Green Infrastructure Projects

\$1,667,330

TOTAL

\$20,173,330±

Appendix A

CSO O&M Plan Checklist

CSO OPERATIONAL PLAN CHECKLIST AND CERTIFICATION

(To be Completed by Permittee)

Facility Name Fox Metro Water Reclamation District

NPDES No. IL 0020818

Section I. The following information should be included in the CSO Operational Plan.

General Information

Included Administrative
Yes No N/A Acceptance

Describe the collection system including all outfalls and overflows, control (diversion) structures, treatment facilities, pumping stations, and associated capacities	<input checked="" type="checkbox"/>	<input type="checkbox"/>	<input type="checkbox"/>	<input type="checkbox"/>	<input type="checkbox"/>
Describe the relationship to other collection entities, esp. other CSO collection entities	<input checked="" type="checkbox"/>	<input type="checkbox"/>	<input type="checkbox"/>	<input type="checkbox"/>	<input type="checkbox"/>
Has the Illinois Pollution Control Board issued any orders, currently in effect, regarding any of these outfalls? <u>If yes, include a copy of the Board Order with the Plan</u>	<input checked="" type="checkbox"/>	<input type="checkbox"/>	<input type="checkbox"/>	<input type="checkbox"/>	<input type="checkbox"/>
Are any of these outfalls to sensitive areas (designated Outstanding National Resource Waters, National Marine Sanctuaries, bathing beaches, shellfish beds, waters with threatened or endangered species and their habitat, contact recreation, or drinking water intakes)? <u>If yes, explain as indicated at the end of Section II</u>	<input type="checkbox"/>	<input checked="" type="checkbox"/>	<input type="checkbox"/>	<input type="checkbox"/>	<input type="checkbox"/>
Describe efforts undertaken to minimize the discharge of pollutants from all CSO outfalls.....	<input checked="" type="checkbox"/>	<input type="checkbox"/>	<input type="checkbox"/>	<input type="checkbox"/>	<input type="checkbox"/>
Describe efforts undertaken to maximize storage of pollutants in the collection system.....	<input checked="" type="checkbox"/>	<input type="checkbox"/>	<input type="checkbox"/>	<input type="checkbox"/>	<input type="checkbox"/>
Describe the pollution prevention aspects of this Operational Plan	<input checked="" type="checkbox"/>	<input type="checkbox"/>	<input type="checkbox"/>	<input type="checkbox"/>	<input type="checkbox"/>
Describe efforts to monitor CSO impacts and the efficacy of CSO controls.....	<input checked="" type="checkbox"/>	<input type="checkbox"/>	<input type="checkbox"/>	<input type="checkbox"/>	<input type="checkbox"/>
Describe the public notification program for CSO occurrences and impacts.....	<input checked="" type="checkbox"/>	<input type="checkbox"/>	<input type="checkbox"/>	<input type="checkbox"/>	<input type="checkbox"/>
Latitude and longitude information given for each outfall.....	<input checked="" type="checkbox"/>	<input type="checkbox"/>	<input type="checkbox"/>	<input type="checkbox"/>	<input type="checkbox"/>

Maintenance

Schedule for regular street cleaning in combined sewer areas	<input checked="" type="checkbox"/>	<input type="checkbox"/>	<input type="checkbox"/>	<input type="checkbox"/>	<input type="checkbox"/>
Added emphasis for leaf removal	<input checked="" type="checkbox"/>	<input type="checkbox"/>	<input type="checkbox"/>	<input type="checkbox"/>	<input type="checkbox"/>
Schedule for catch basin cleaning	<input checked="" type="checkbox"/>	<input type="checkbox"/>	<input type="checkbox"/>	<input type="checkbox"/>	<input type="checkbox"/>
Schedule for routine cleaning of trunk and interceptor sewers	<input checked="" type="checkbox"/>	<input type="checkbox"/>	<input type="checkbox"/>	<input type="checkbox"/>	<input type="checkbox"/>
Stop planks at highest level practical without causing basement backups or excessive street flooding	<input checked="" type="checkbox"/>	<input type="checkbox"/>	<input type="checkbox"/>	<input type="checkbox"/>	<input type="checkbox"/>
Date system stop planks last adjusted	<input checked="" type="checkbox"/>	<input type="checkbox"/>	<input type="checkbox"/>	<input type="checkbox"/>	<input type="checkbox"/>
Describe your procedures for:					
Cleaning screening equipment after and, if necessary, during each storm	<input checked="" type="checkbox"/>	<input type="checkbox"/>	<input type="checkbox"/>	<input type="checkbox"/>	<input type="checkbox"/>
Regulating diversion and bypass valves.....	<input checked="" type="checkbox"/>	<input type="checkbox"/>	<input type="checkbox"/>	<input type="checkbox"/>	<input type="checkbox"/>
Reducing solids deposition in the combined sewer system.....	<input checked="" type="checkbox"/>	<input type="checkbox"/>	<input type="checkbox"/>	<input type="checkbox"/>	<input type="checkbox"/>

Inspections and Monitoring

Schedule to inspect regulator and diversion structures included	<input checked="" type="checkbox"/>	<input type="checkbox"/>	<input type="checkbox"/>	<input type="checkbox"/>	<input type="checkbox"/>
Routine pump/lift station inspection and preventive maintenance discussed	<input checked="" type="checkbox"/>	<input type="checkbox"/>	<input type="checkbox"/>	<input type="checkbox"/>	<input type="checkbox"/>
Schedule to inspect manholes and sewers (e.g., televise, etc.) included	<input checked="" type="checkbox"/>	<input type="checkbox"/>	<input type="checkbox"/>	<input type="checkbox"/>	<input type="checkbox"/>
Schedule to inspect surface water anti-intrusion devices (e.g., flapgates, etc.).....	<input checked="" type="checkbox"/>	<input type="checkbox"/>	<input type="checkbox"/>	<input type="checkbox"/>	<input type="checkbox"/>
Describe your procedures for finding and eliminating illegal sewer connections	<input checked="" type="checkbox"/>	<input type="checkbox"/>	<input type="checkbox"/>	<input type="checkbox"/>	<input type="checkbox"/>
Describe your procedures for finding and eliminating dry-weather overflows.....	<input checked="" type="checkbox"/>	<input type="checkbox"/>	<input type="checkbox"/>	<input type="checkbox"/>	<input type="checkbox"/>

Section II. Information in the following section should be included in the Plan and kept on file by the permittee. This information will be verified by IEPA during a facility inspection. The submission of the information in Section II to the Agency should only be done when requested. **DO NOT SUBMIT THE INFORMATION REQUESTED IN THE FOLLOWING SECTION WITH THE CSO OPERATIONAL PLAN.**

Maps and Diagrams

Included IEPA Field
Yes No N/A Verification

Sewer system map included	<input checked="" type="checkbox"/>	<input type="checkbox"/>	<input type="checkbox"/>	<input type="checkbox"/>	<input type="checkbox"/>
Combined sewers and sanitary sewers tributary to combined sewers marked	<input checked="" type="checkbox"/>	<input type="checkbox"/>	<input type="checkbox"/>	<input type="checkbox"/>	<input type="checkbox"/>
Storm sewers using combined sewers as a transport link marked.....	<input checked="" type="checkbox"/>	<input type="checkbox"/>	<input type="checkbox"/>	<input type="checkbox"/>	<input type="checkbox"/>
All major interceptors and trunk sewers marked.....	<input checked="" type="checkbox"/>	<input type="checkbox"/>	<input type="checkbox"/>	<input type="checkbox"/>	<input type="checkbox"/>
Sewer sizes, slope, and material indicated	<input type="checkbox"/>	<input checked="" type="checkbox"/>	<input type="checkbox"/>	<input type="checkbox"/>	<input type="checkbox"/>
Manholes and catch basins identified	<input checked="" type="checkbox"/>	<input type="checkbox"/>	<input type="checkbox"/>	<input type="checkbox"/>	<input type="checkbox"/>
All CSOs, treatment plant bypasses, outfalls, and their receiving waters identified.....	<input checked="" type="checkbox"/>	<input type="checkbox"/>	<input type="checkbox"/>	<input type="checkbox"/>	<input type="checkbox"/>
All control (diversion) structures, including valves, marked.....	<input checked="" type="checkbox"/>	<input type="checkbox"/>	<input type="checkbox"/>	<input type="checkbox"/>	<input type="checkbox"/>
All pump and lift stations and their capacities marked	<input checked="" type="checkbox"/>	<input type="checkbox"/>	<input type="checkbox"/>	<input type="checkbox"/>	<input type="checkbox"/>
Diagram of CSO Treatment Facilities	<input checked="" type="checkbox"/>	<input type="checkbox"/>	<input type="checkbox"/>	<input type="checkbox"/>	<input type="checkbox"/>
All unit processes and associated capacities identified	<input checked="" type="checkbox"/>	<input type="checkbox"/>	<input type="checkbox"/>	<input type="checkbox"/>	<input type="checkbox"/>

FOX METRO WATER RECLAMATION DISTRICT

Permit No. IL 0020818

CSO O&M PLAN CHECKLIST: Attached sheet

Explain all No and N/A questions on a separate sheet and attach.

Maps and Diagrams

Sewer system map included: Sewer sizes, slope, and materials indicated. We have the sewer sizes but not the slope or materials for the entire system.

Sewer System Characterization

Drainage area and population tributary to each overflow indicated. We have the drainage area but not the population information available.

We do not have any of the following information but will update the checklist form if the information becomes available in the future:

List of non-residential sewer users tributary to each overflow

Dischargers of toxics indicated

Dischargers of high strength wastewater indicated

High-volume dischargers indicated

Percent pervious area developed and kept current for each sewerage basin

Appendix B

Figures 1-18: Overview and Tributary Basins

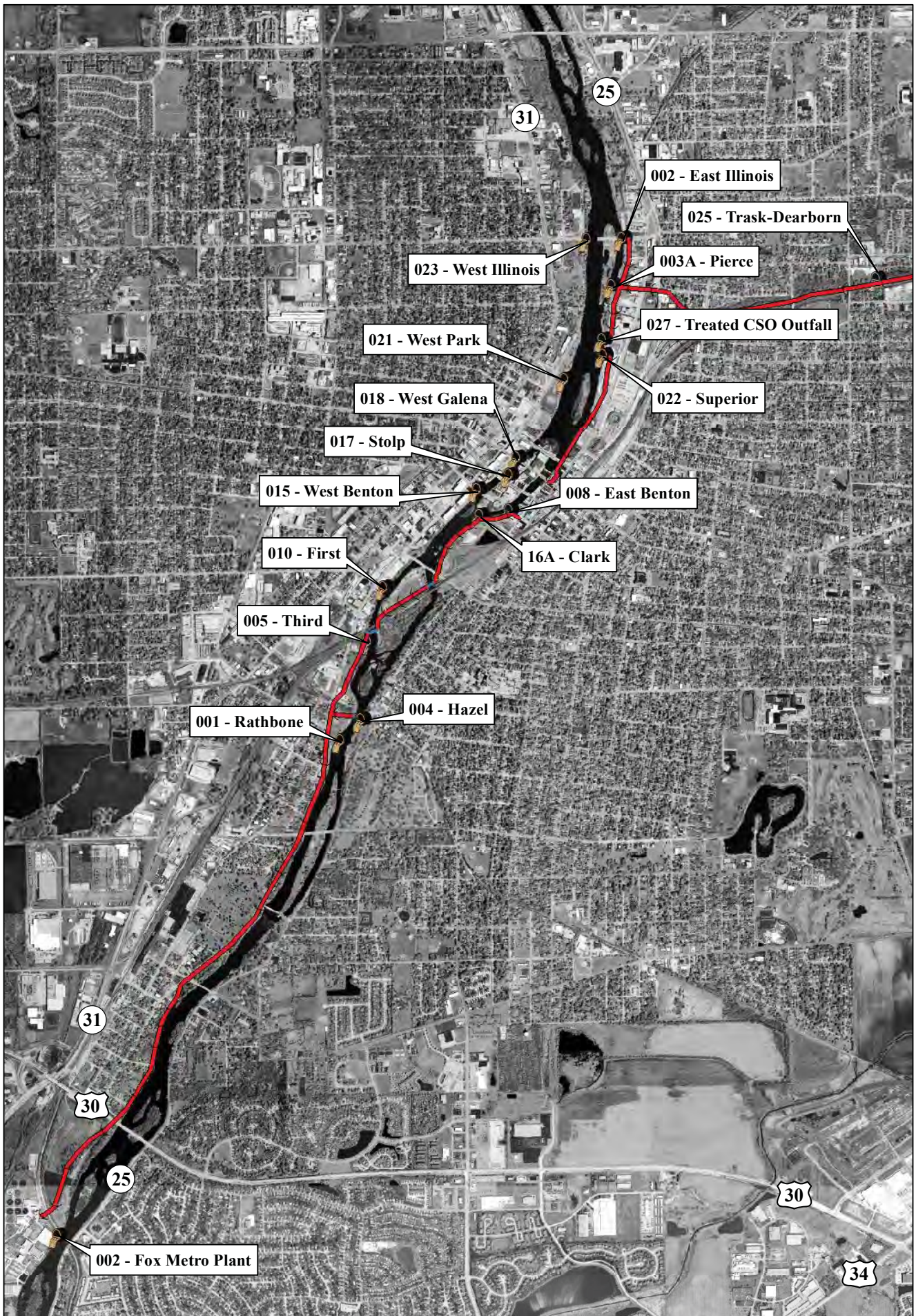
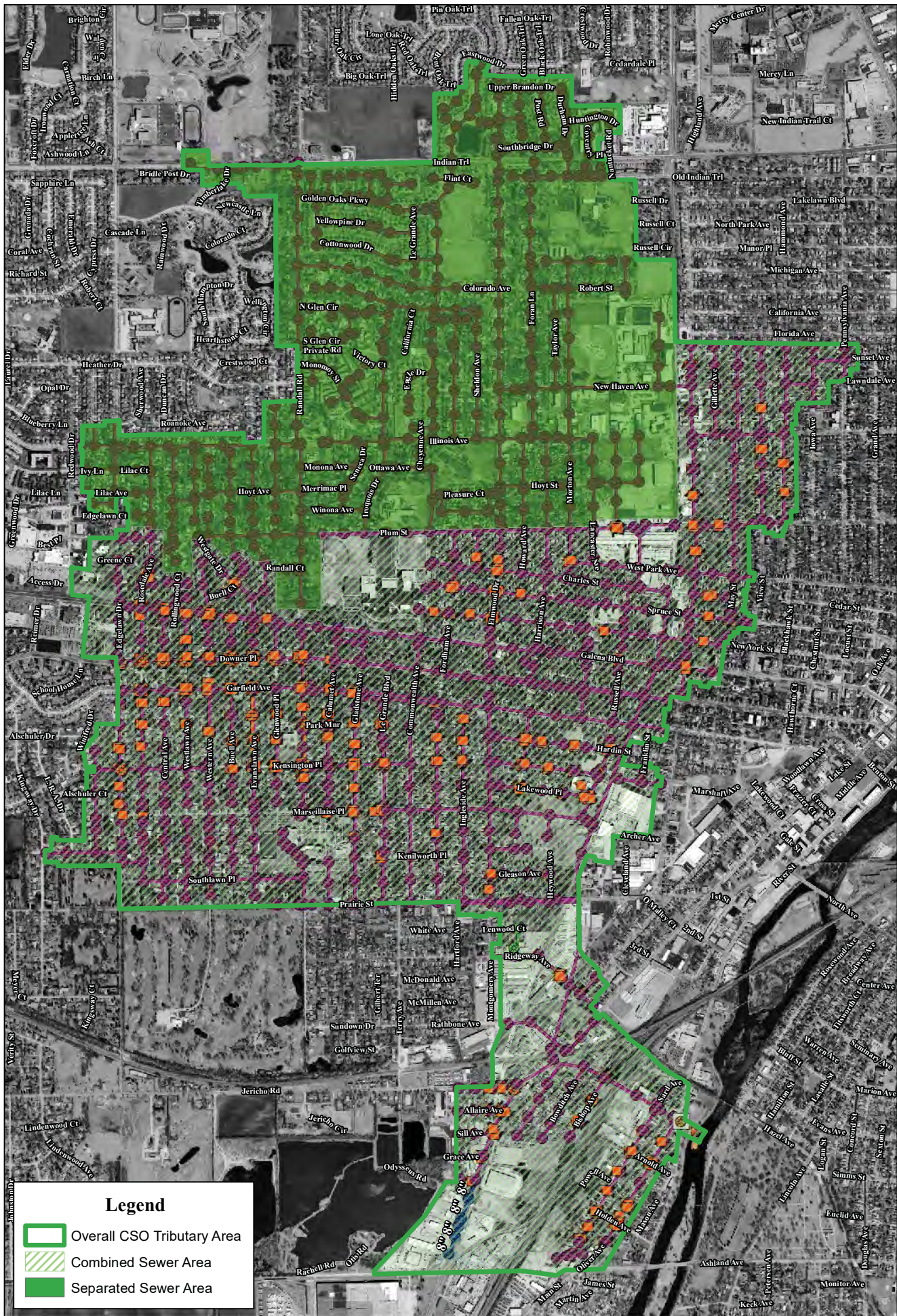

Figure 1
Fox Metro Water Reclamation District
CSO Overview Map



Legend

- Overall CSO Tributary Area
- Combined Sewer Area
- Separated Sewer Area

Figure 2
City of Aurora CSO - 001
Rathbone





Legend



-  Overall CSO Tributary Area
-  Combined Sewer Area
-  Separated Sewer Area

Figure 3
City of Aurora CSO - 002
East Illinois



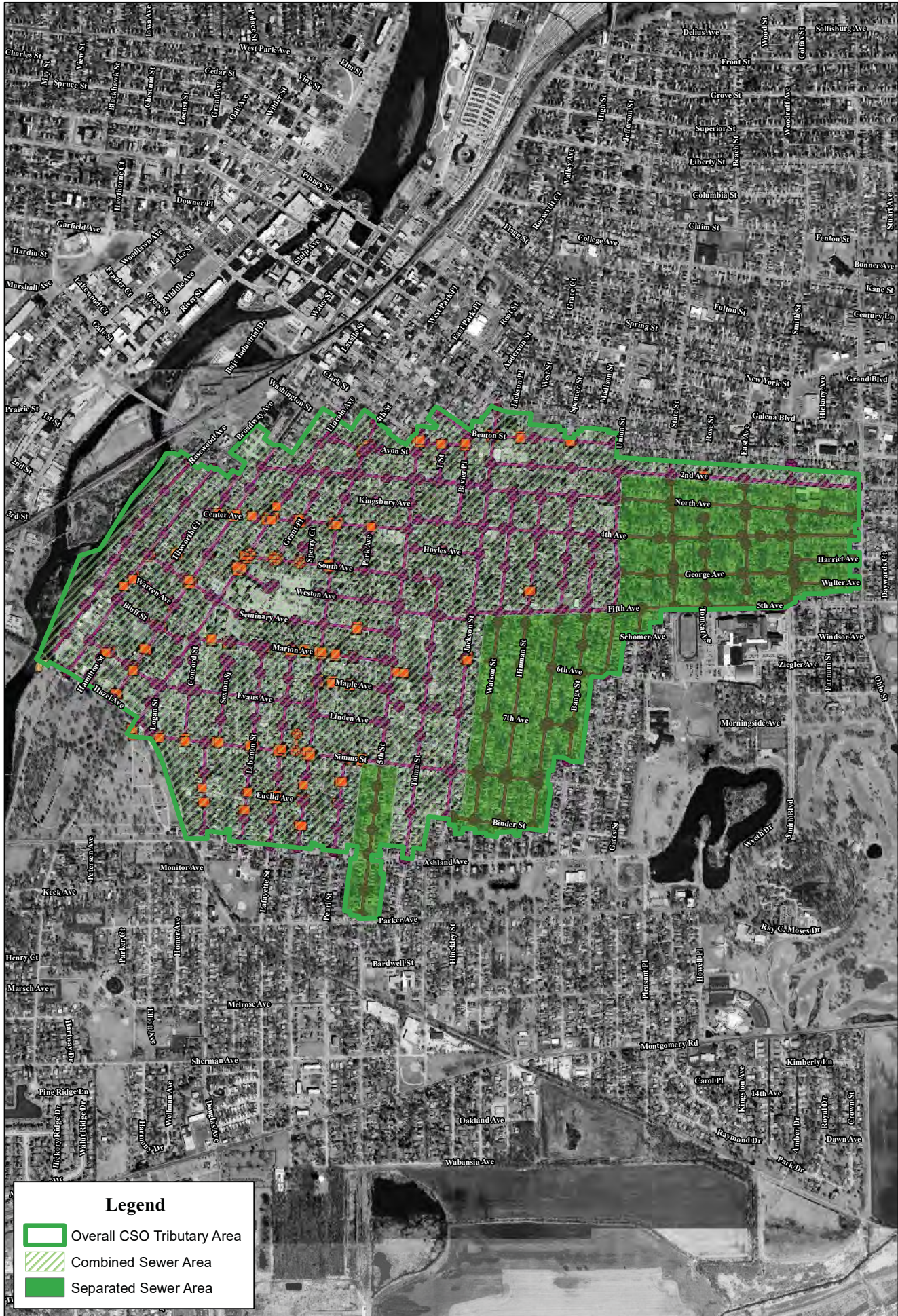
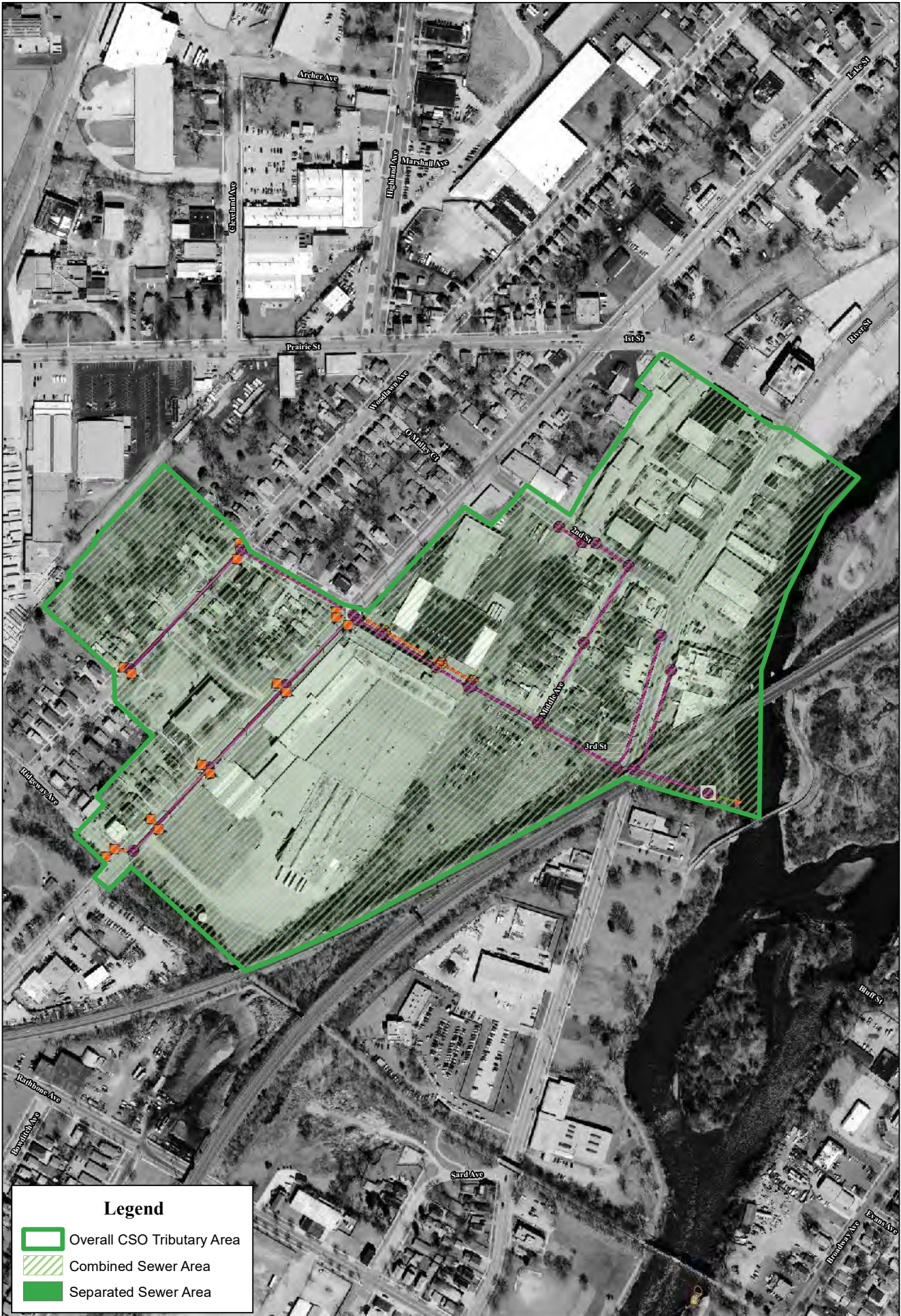

Figure 5
City of Aurora CSO - 004
Hazel





Legend

- Overall CSO Tributary Area
- Combined Sewer Area
- Separated Sewer Area

Figure 6
City of Aurora CSO - 005
Third





Legend

- Overall CSO Tributary Area
- Combined Sewer Area
- Separated Sewer Area

Figure 7
City of Aurora CSO - 008
East Benton





Legend



-  Overall CSO Tributary Area
-  Combined Sewer Area
-  Separated Sewer Area

Figure 8
City of Aurora CSO - 010
First





Figure 9
City of Aurora CSO - 015
West Benton





Legend



-  Overall CSO Tributary Area
-  Combined Sewer Area
-  Separated Sewer Area

Figure 10
City of Aurora CSO - 16A
Clark





Legend

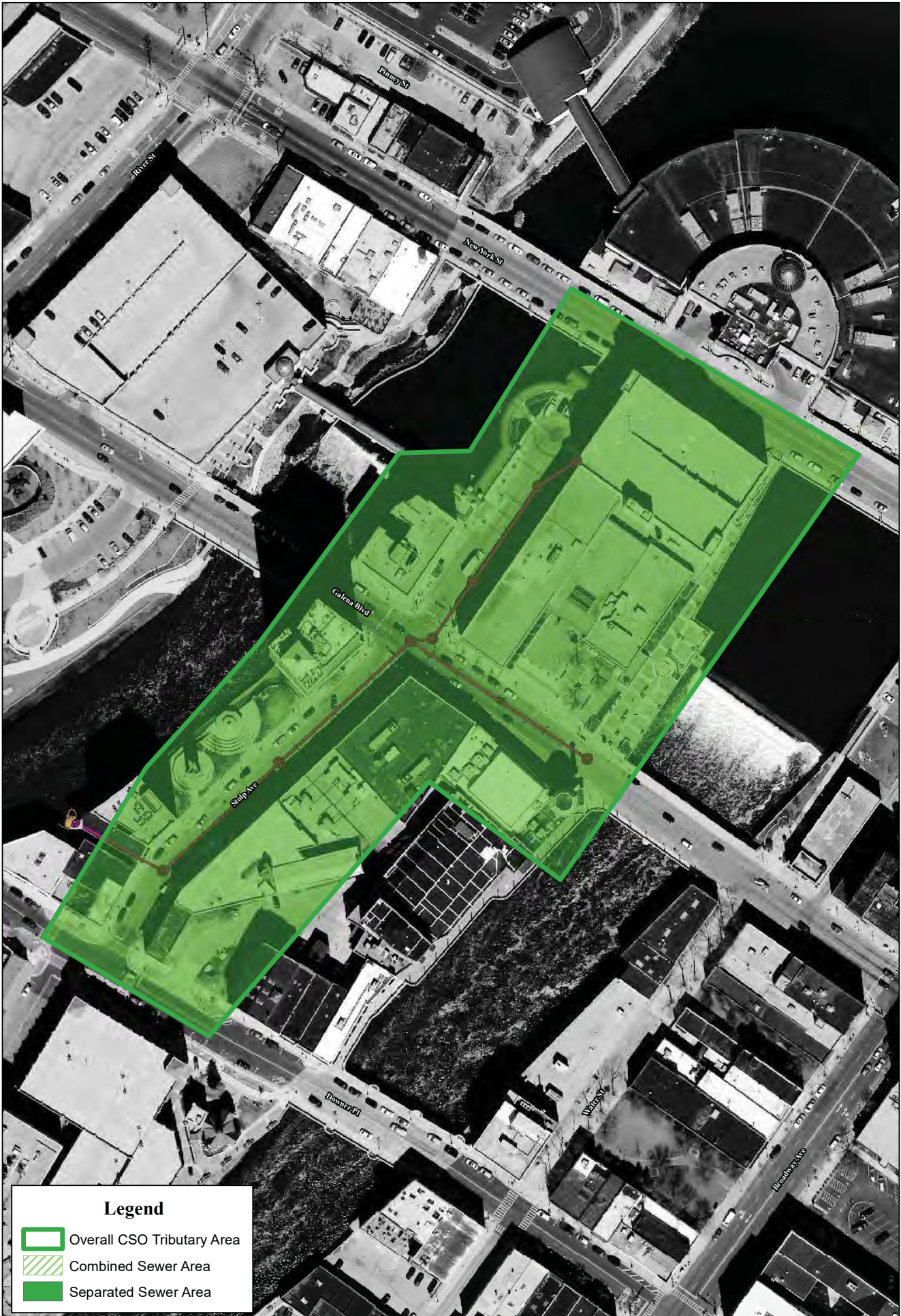

-  Overall CSO Tributary Area
-  Combined Sewer Area
-  Separated Sewer Area

Figure 11
City of Aurora CSO - 017
Stolp





Legend

- Overall CSO Tributary Area
- Combined Sewer Area
- Separated Sewer Area



Figure 12
City of Aurora CSO - 018
West Galena





Legend

- Overall CSO Tributary Area
- Combined Sewer Area
- Separated Sewer Area



Figure 13
City of Aurora CSO - 021
West Park





Legend



-  Overall CSO Tributary Area
-  Combined Sewer Area
-  Separated Sewer Area

Figure 15
City of Aurora CSO - 023
West Illinois



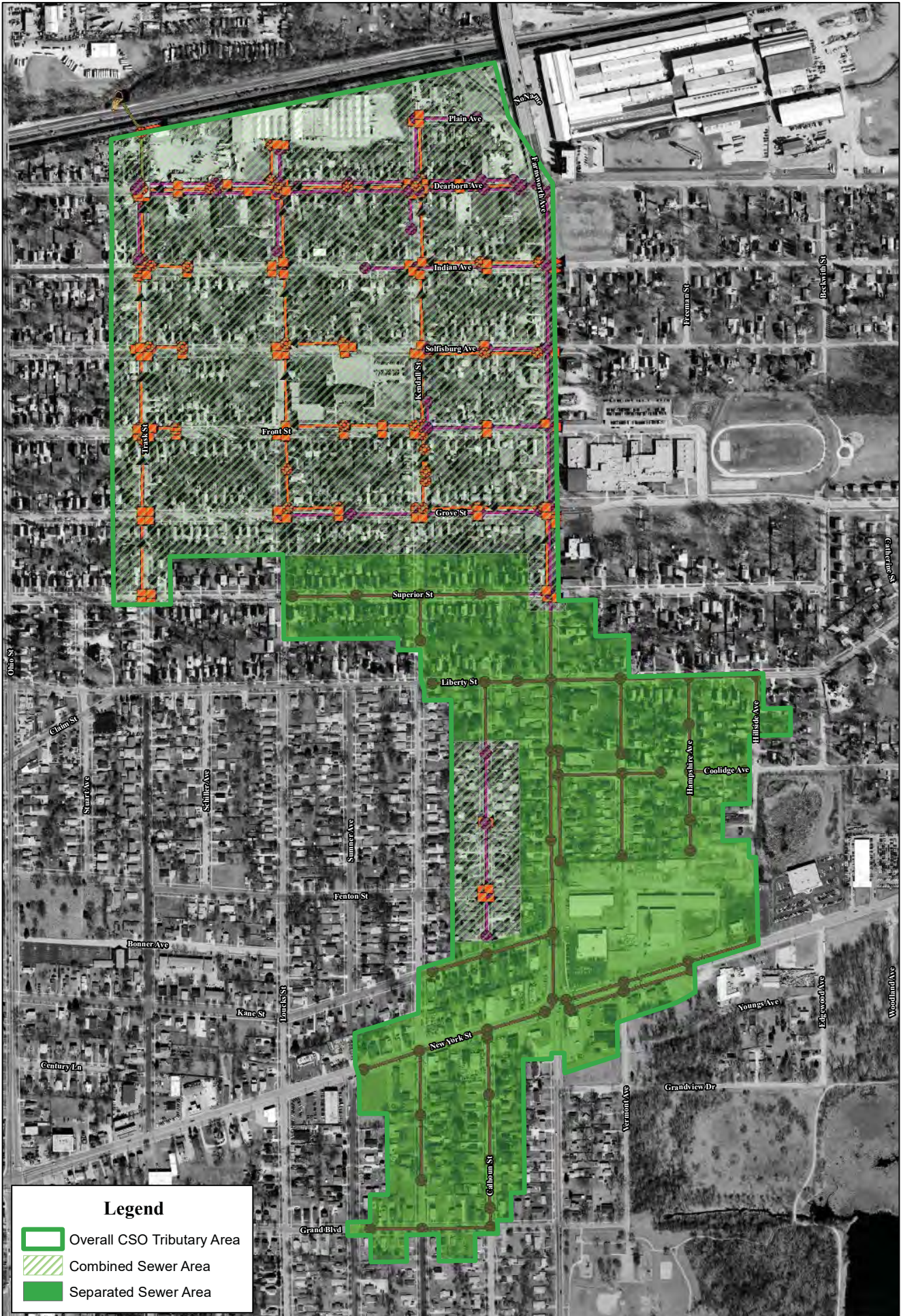

Legend

- Overall CSO Tributary Area
- Combined Sewer Area
- Separated Sewer Area

Figure 16
City of Aurora CSO - 025
Trask-Dearborn





Legend



-  Overall CSO Tributary Area
-  Combined Sewer Area
-  Separated Sewer Area

Figure 17
City of Aurora CSO - 027
Treated CSO Outfall





Figure 18
Fox Metro CSO - 002
Fox Metro Plant



Appendix C

IPCB Ruling #85-224

ILLINOIS POLLUTION CONTROL BOARD
June 21, 1990

IN THE MATTER OF:)
)
JOINT PETITION OF THE AURORA SANITARY)
DISTRICT, THE CITY OF AURORA, AND THE)
ILLINOIS ENVIRONMENTAL PROTECTION) PCB 85-224
AGENCY FOR EXCEPTION TO THE COMBINED) (CSO Exception)
SEWER OVERFLOW (CSO) REGULATIONS)

ORDER OF THE BOARD (by R.C. Flemal):

This matter comes before the Board on a Motion for Modification of a Board Order filed June 14, 1990 by Aurora Sanitary District ("ASD"), the City of Aurora, and the Illinois Environmental Protection Agency.

The Board's final Order in this matter, in which the Board granted the CSO exception, was entered on July 13, 1988. Conditions attached to the grant of exception include certain construction and operational requirements imposed on the ASD as found at Condition (paragraph) #3 of the July 13 Order. Among other matters, Condition #3 does not specify a date certain upon which these requirements are to be in effect.

Subsequent to entry of the July 13 Board Order, the ASD obtained a State of Illinois Loan to enable it to carry out the requirements of Condition #3. A condition of the loan is that Condition #3 be modified to reflect a completion date of July 1, 1992. Petitioners accordingly now request that the Board so modify Condition #3.

Petitioners' motion is granted. Condition #3 of the Board's Order in this matter of July 13, 1988 is hereby amended to read as follows:

3. The Aurora Sanitary District Treatment facility shall be operated in accordance with the following provisions, effective July 1, 1992:
 - a. All flows received at the treatment plant must be screened and metered.
 - b. All flows up to 74 million gallons per day ("MGD") must receive a minimum of primary clarification prior to and during any occurrence of bypassing.
 - c. All flows up to 68 MGD must receive full treatment prior to and during any occurrence of bypassing ahead of or following primary treatment units.

IT IS SO ORDERED.

Board Member J.D. Dumelle concurred.

I, Dorothy M. Gunn, Clerk of the Illinois Pollution Control Board, hereby certify that the above Order was adopted on the 21st day of JUNE, 1990, by a vote of 7-0.

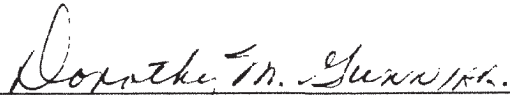

Dorothy M. Gunn, Clerk
Illinois Pollution Control Board

ILLINOIS POLLUTION CONTROL BOARD
July 13, 1988

IN THE MATTER OF:)
)
JOINT PETITION OF THE AURORA SANITARY)
DISTRICT, THE CITY OF AURORA, AND THE)
ILLINOIS ENVIRONMENTAL PROTECTION) PCB 85-224
AGENCY FOR EXCEPTION TO THE COMBINED)
SEWER OVERFLOW (CSO) REGULATIONS)

OPINION AND ORDER OF THE BOARD (by R.C. Flemal):

This matter comes before the Board on a December 31, 1985 joint petition filed by the Aurora Sanitary District ("ASD") and the City of Aurora ("City") (hereinafter collectively referred to as "Aurora") and the Illinois Environmental Protection Agency ("Agency") for exception to 35 Ill. Adm. Code 306.305 (a) and (b) to relieve Aurora from the requirement to construct and operate certain combined sewer overflow ("CSO") transport and treatment facilities.

Hearing was held at the Aurora City Hall on March 6, 1986. On June 6, 1986 Petitioners filed a Proposed Order ("Proposed Order"). On June 20, 1986 the petition was remanded to the Petitioners by Board Order. On March 27, 1987 Petitioners filed an Amended Joint Petition ("Amended Pet."). On July 1, 1988 Petitioners filed a Second Amended Joint Petition ("2nd Amended Pet."). No additional hearing has been held.

For the reasons described below, the Board finds that Petitioners have made the showings requisite for granting the relief requested. The relief will accordingly be granted, subject to conditions as stipulated to by Petitioners and consistent with the Board's rules and regulations.

CSO REGULATIONS

The Board's CSO regulations are contained in 35 Ill. Adm. Code Subtitle C, Chapter I, Part 306. They were amended in R81-17, 51 PCB 383, March 24, 1983. Sections pertinent to the instant matter are Sections 306.305 and 306.361(a). Section 306.305 provides as follows:

All combined sewer overflows and treatment plant bypasses shall be given sufficient treatment to prevent pollution, or the violation of applicable water standards unless an exception has been granted by the Board pursuant to Subpart D.

Sufficient treatment shall consist of the following:

- a) All dry weather flows, and the first flush of storm flows as determined by the Agency, shall meet the applicable effluent standards; and
- b) Additional flows, as determined by the Agency but not less than ten times average dry weather flow for the design year, shall receive a minimum of primary treatment and disinfection with adequate retention time; and
- c) Flows in excess of those described in subsection (b) shall be treated, in whole or in part, to the extent necessary to prevent accumulations of sludge deposits, floating debris and solids in accordance with 35 Ill. Adm. Code 302.203, and to prevent depression of oxygen levels; or
- d) Compliance with a treatment program authorized by the Board in an exception granted pursuant to Subpart D.

Subpart D allows the discharger to file a petition for an exception either singly, or jointly with the Agency as Aurora has done. A joint petition may seek an exception based on minimal discharge impact as provided in Section 306.361(a):

An exception justification based upon minimal discharge impact shall include, as a minimum, an evaluation of receiving stream ratios, known stream uses, accessibility to stream and side land use activities (residential, commercial, agricultural, industrial, recreational), frequency and extent of overflow events, inspections of unnatural bottom deposits, odors, unnatural floating material or color, stream morphology and results of limited stream chemical analyses.

Pursuant to 306.361(a) Aurora and the Agency assert that overflows from its combined storm and sanitary sewer system have minimal impact on the water quality of, and do not restrict the use of, the Fox River and Indian Creek (the receiving streams).

SUPPORT DOCUMENTS

Petitioners have presented several documents in support of their petition. Included among these is a two-volume combined sewer overflow study undertaken by Walter E. Deuchler Associates, Inc. This document was attached to the Petition and Amended Petition as Attachment A; it was also admitted as hearing exhibit

1. Among other matters, the study contains analysis of impact of the existing CSOs on the Fox River and the reduction of flow and pollutant loads that can be expected from implementation of several CSO options.

In response to concerns as expressed by the Board in its June 20, 1986 Order, Petitioners commissioned and submitted a study: "An Assessment of Indian Creek Bottom Sediments in the Vicinity of Combined Sewer Overflow 25 in Aurora, Illinois", Illinois State Water Survey Contract Report 412, January 1987. This report is Appendix G to the Amended Petition of March 27, 1987.

On January 28, 1988 Aurora completed a study, as an amendment to its Municipal Compliance Plan, which provides an update on relief sewer projects undertaken as part of the overall CSO program. This report was submitted to the Board along with the 2nd Amended Pet as Exhibit I.

BACKGROUND

The ASD provides wastewater treatment for Aurora, North Aurora, Montgomery, Boulder Hill, and part of Oswego. Its facility plan area encompasses portions of DuPage, Kane, Kendall, and Will Counties. The population currently served by the ASD is approximately 120,000, with a projected population for the year 2003 of 193,000 (R. at 12).

The ASD's only treatment plant is located west of the Fox River and south of Montgomery, Illinois. The plant provides preliminary treatment, primary clarification, biological oxidation and nitrification, tertiary sand filtration, and chlorine disinfection. It has a design average flow capacity of 32 mgd, with a design maximum flow capacity of 68 mgd (R. at 12). Discharge is to the Fox River.

The City of Aurora has both combined and separate sanitary sewer systems, while the remainder of the service area has separate sanitary and storm sewers. The City's combined sewers serve approximately 4,360 acres (6.9 sq. mi.) of the approximately 50 square miles served by the ASD (R. at 52, 89). No new combined sewers have been constructed since 1937 pursuant to a city ordinance (R. at 52).

The system has fourteen CSO overflow points (Amended Pet. at 3). Thirteen are located within the City and one is located at the ASD plant. All of the discharges are directly to the Fox River, with the exception of one City point which discharges to Indian Creek. The overflows occur primarily at diversion structures which serve to limit wet weather flow to the treatment plant. Four of the City overflow points are considered major by

the Petitioners because they collectively receive flow from more than two thirds of the land areas within the City served by combined sewers. These four points, plus the ADS treatment plant overflow, account for 79% of the total overflow volume. The remaining nine City overflow points are considered minor by the Petitioners in that they collectively receive flow from less than 1/3 of the acreage served by the combined sewers and account for only 21% of overflows (Id. at 3-4). The major City overflow points are numbered 1, 4, 8, and 25; 1, 4, and 8 are located at the Fox River at Rathbone Avenue, Hazel Avenue, and Benton Street, respectively; CSO 25 is tributary to Indian Creek.

CONTROL AND IMPACT-REDUCTION OPTIONS

Aurora has investigated options by which it might moot the need for the relief requested, or, in the alternative, minimize the impact of its CSOs. Six options were considered, including: (1) complete elimination of all combined sewers, (2) construction of facilities necessary to achieve compliance under Section 306.305, and (3) four options - identified in the record as Alternatives A, B, C, and D - which provide for progressively greater reduction in the impact of existing CSOs.

Elimination of all existing combined sewers is estimated to cost at least \$160 million¹ (Amended Pet. at 14).

Full compliance with Section 306.305 could be achieved by providing the necessary treatment to combined sewer discharges. The required facilities would include large storage basins at four locations and several relief sewers to assure hydraulic capacity for all first flush flow. Additionally, three treatment facilities with a combined capacity of 51 mgd would be required at the ASD plant to provide treatment for flows up to 10 x average dry weather flow. The total cost of these facilities is approximately \$99 million (Amended Pet. at 14).

Petitioners contend that neither the complete CSO elimination option nor the 306.305 compliance option is cost effective (Amended Pet. at 4), and, moreover, that neither would materially improve the water quality or enhance any beneficial uses of the Fox River (R. at 15). Accordingly, Petitioners have turned to the options which would at least reduce CSO impact.

Petitioners have opted to pursue and present to the Board Alternative D, which provides the greatest impact reduction among the four alternatives. Alternative D is designed to assure:

¹ Control option cost figures cited herein are in 1986 dollars.

- 1) Complete treatment of peak dry weather flow;
- 2) Complete treatment of up to 2.5 x average dry weather flow;
- 3) Complete treatment of 57% of first flush; and
- 4) Complete or primary treatment of 65% of flows in excess of 2.5 x average dry weather flow.

Amended Pet. at 5

Alternative D would conservatively² also cause a 58.9% reduction in CSO flows and a reduction in pollutant loads ranging from 50.1% for suspended solids to 77.5% for phosphate (Id. at 6).

At \$22.25 million, Alternative D is the most costly of the four impact-reduction options (Amended Pet. at 13-18). Among the activities to be undertaken are sewer separations, addition and replacement of sewer pipes, modification of siphon and weir structures, re-routing of combined sewer flows, implementation of inflow/infiltration reduction strategies, and elimination of one CSO. Aurora has stipulated to carrying out these improvements, and Petitioners request (Proposed Order at 1-2) that they be listed in the Board's Order.

Aurora additionally stipulates to a schedule for completion of the improvements (Amended Pet., Appen. G, as modified in 2nd Amended Pet.), and Petitioners request that this schedule also be incorporated into the Board's Order. However, the Board notes that both the internal and final completion dates for all but two of the many individual projects within the program are now past. Presumably, therefore, all but two of the projects are now complete. For this reason the Board will condition the grant of relief only upon the agreed-upon final dates.

DOCUMENTATION OF MINIMAL IMPACT

Section 306.361(a) requires that Petitioners seeking a CSO exception on the basis of minimal discharge impact, as is the case here, make a number of showings. Pursuant thereto, Petitioners provide the following information and observations:

² Calculation of CSO impacts under Alternative D was made prior to certain additional improvements made to the Alternative D program at the Agency's suggestion. The precise impact of these additional improvements has not been determined, and is therefore not reflected in the Alternative D impact figures (Amended Pet. at 5, 7).

Receiving Stream Ratios

The average discharge of the Fox River at Aurora is approximately 1,810 cubic feet per second ("cfs"). The average CSO flow rate from all City and ASD overflow points is 3.9 cfs, or 0.20% of the average river discharge. Petitioners also contend that pollution loading of the CSOs is small relative to the load of the Fox River. In support thereof, Petitioners present the following data:

	Total Load (tons/yr)	CSO CONTRIBUTION		
		Prior to Alt. D (tons/yr)	Percent	After Alt. D (Percent)
BOD	26,800	350	1.30	.40
Ammonia-Nitrogen	530	16	3.02	.79
Nitrate-Nitrogen	3,550	2.1	.06	.02
Phosphate	710	1.9	.27	.06

From these data Petitioners concluded that "[i]t is thus apparent that the extremely low ratios of CSO flow and pollutant loads to Fox River flow and pollutant loads assure that the City and ASD CSOs have no significant impact on Fox River water quality" (Amended Pet. at 7).

Indian Creek is an intermittent stream with a ten-year, seven-day low flow of zero (Amended Pet. at 7).

Known Stream Uses

Petitioners report that a 1981 Northeastern Illinois Planning Commission study listed the following uses for the Fox River in Kane County:

- (i) fishing;
- (ii) canoeing;
- (iii) other types of pleasure boating;
- (iv) picnicking, fishing, hiking, etc., in public parks along the shore;
- (v) agricultural drainage;
- (vi) "urban drainage" from commercial and residential land along the river;
- (vii) receiving effluents from several wastewater treatment plants and overflow diversion structures.

Petitioners additionally point out that the Fox River in the CSO study area is abutted for the most part by commercial and residential properties (Amended Pet. at 8). They also note that "Indian Creek is basically an urban drainage channel" for its lower 3 to 4 miles, although in its upper reaches it receives runoff from farmlands (Id.).

Accessibility to Stream Side Land Use Activities

Regarding accessibility to stream-side land, Petitioners note:

The combined sewer portion of the ASD service area consists almost exclusively of residential and commercial establishments. Agricultural land and open space account for but a small fraction of acreage abutting the river in the ASD service area. Some light manufacturing plants and warehouses abut the river in the southwest portion of the combined sewer area. (Appendix A at p. 2-5). Exhibit 4 to the CSO study details the riparian land use in the CSO area. Generally, the river is not readily accessible to the general public, with the exception of boaters who use two designated "boat access areas" in the City of Aurora.

Indian Creek is, for the most part, within the Burlington Northern Railroad right of way and the activities along the stretch both immediately upstream and downstream of OVF. No. 25 can be characterized as industrial.

Amended Pet. at 8-9.

Frequency and Extent of Overflow Events

The CSO study (Ex. 1) estimates that 1,187 overflow events per year, with a total yearly flow of 914 million gallons, occurred prior to implementation of Alternative D. Of these, 663 events and 568 million gallons were attributable to the major overflow points 1, 4, 8, and 25. Full implementation of Alternative D is expected to reduce yearly overflow events to 658 and total overflow volume to 375 million gallons, reductions of 44.5% and 59.0%, respectively (Amended Pet. at 9; see also footnote 2).

Inspections of Outfalls (Bottom Deposits, Odors, etc.)

Regarding inspections of unnatural bottom deposits, Petitioners note:

In June, 1983, the Fox River was examined for sludge deposits, sewer-related odors, sediment in quiet portions of the river, and sewer-related impact on vegetation. The purpose of the inspections was to determine if CSOs significantly contributed to sludge deposits or adverse environmental impacts.

The CSO study details inspection locations, methods and results. (Appendix A at pp. 3-5 to 3-11). To summarize, approximately 30 locations in the river, including points upstream and downstream of all CSO points, were examined for sediment depth, color, texture and odor. At the same time depth of water, the size of the stream-bed area examined, and the amount and nature of floating debris, if any, were noted. The inspections revealed that, with the exception of the shoreline areas, most of the river bottom is rock or gravel with no sludge deposits. However, some sludge deposits were noted in low velocity areas -- i.e., near shorelines and downstream of islands. Sewage-related odors were detectable at a few small and localized areas near CSO outfalls. Although a relatively large area of sludge deposits was noted upstream of all CSO points, no comparable deposits were found downstream of the overflow points. The study concludes that there is no correlation between the overflow points and sludge deposits in the Fox River in the Aurora CSO areas. (Appendix A at p. 3-11).

In addition to inspecting the river, the contractor reviewed a 1978 NIPC study of sediment oxygen demand in the Fox River. The study showed varying sediment oxygen demands at five different locations in the river. However, no relation between sediment oxygen demand and CSOs could be detected. In fact, of the five sampling points, the highest sediment oxygen demand was found upstream of all of the overflow points. (Appendix A at pp. 2-5 to 2-8).

The Agency survey (Appendix D at p. 4) shows black septic sludge at the site of overflow No. 25. Further investigations reveal that the most severe incidence of bottom deposits is limited to 500 or 600 feet downstream of the overflow.

As noted above, sewage-related odors were detected in localized areas near a few CSO outfalls. (Appendix A at 3-11). Odors are moderate to severe near Overflow No. 25, but they can be detected for some distance downstream (+500 ft.) and intermittently throughout Indian Creek.

No unnatural colors were noted in the course of the river inspection. Floating debris was found in several locations, but all floating materials noted were unrelated to sewer overflows -- the specific items noted were tree branches, drums, tires, cardboard boxes and pipes. (Appendix A at pp. 3-6 to 3-10).

Rags, tissue paper, etc. were observed in brush and log jams immediately below OVF No. 25 up to a distance of approximately 200 feet downstream.

Amended Pet. at 9-11

Pursuant to concerns raised at hearing and to the Board's Order of June 20, 1986 Petitioners have caused further investigation of CSO impacts on Indian Creek. In particular, a study was undertaken by the Illinois State Water Survey and reached the following conclusions (Amended. Pet., Appendix G at 9-10):

- a) Indian Creek below overflow 25 exhibits some benthic sediment degradation. However, this degradation is relatively minor and is in line with that of other streams receiving intermittent combined sewage overflows or a steady flow of well-treated effluent.
- b) Benthos and phytoplankton productivity is low both upstream and downstream of the outfall.
- c) The stream supports lush and extensive periphyton growth. Sediment oxygen demand is contributed by bottom-dwelling diatoms, iron bacteria respiration, and ammonia oxidation. The latter accounts for almost two-thirds of the sediment oxygen demand in the outfall area, but none of the sediment oxygen demand at a station above the outfall.
- d) Gross visual and aesthetic pollution due to discharges from overflow 25 was not evident.
- e) A reduction in the frequency and quantity of the CSO probably would enhance downstream conditions.

Petitioners further note that the sediment oxygen demands of Indian Creek are comparable to those of the Fox River (Amended Pet. at 19), and that the impacts of overflow 25 appear to be localized to the first 600 feet downstream of the outfall (Id.).

Stream Morphology

The condition of the Fox River through Aurora has been described in a Northeastern Illinois Planning Commission 1981 stream use inventory as "natural" with scarce aquatic vegetation and "fair to good" aesthetic appeal (Amended Pet. at 11). The streamside vegetation was noted to be "mature forest/brush" (Id.). Petitioners further note that the river is locally free

of log jams and other accumulations of vegetative debris and that the river substrate is rock or gravel; some channelization has occurred in the highly-developed areas (Id. at 11-12).

Indian Creek has a relatively steep gradient and flows in a series of riffles and pools (Amended Pet. at 12).

Stream Chemical Analyses

Aurora undertook a sampling of CSO water quality and instream water quality during two storm events in 1981 (See Ex. 1 at 3-1 to 3-4 and Appendix B; Exhibit 10; Exhibit 11). From these data Petitioners conclude that "there appears to be little if any correlation between the combined sewer overflows and Fox River water quality during and after rainfalls" (Amended Pet. at 13). No chemical analyses were conducted on Indian Creek because the Petitioners "assumed that during the time overflow is active, the creek would reflect basically degraded conditions" (Id.).

CONCLUSION

The Board determines that Petitioners have shown pursuant to 35 Ill. Adm. Code 306.361(a) that exception to 35 Ill. Adm. Code 306.305(a), as it relates to first flush of storm flows, and to 35 Ill. Adm. Code 306.305(b) would produce minimal impact on the receiving stream. Accordingly, the Board will grant the exception. The Board further will accept the conditions as agreed to by Petitioners in their June 6, 1986 Proposed Order as modified in the Amended Petition of March 27, 1987 and Second Amended Petition of July 1, 1988.

ORDER

Aurora Sanitary District and the City of Aurora are hereby granted an exception from combined sewer overflow regulations 35 Ill. Adm. Code 306.305 (a) as it relates to first flush storm flows, and to 35 Ill. Adm. Code 306.305 (b), subject to the following conditions:

1. The City and District shall implement the following system improvements:
 - a. Provide an additional 15" diameter connecting pipe at overflow No. 1 located at Rathbone Avenue.
 - b. Modify the existing west siphon chamber at Hurd's Island to facilitate maintenance, and provide a manhole at the bend in the interceptor just north of the railroad bridge.

- c. Remove siphon over Western United Gas and Electric Co. discharge tunnels and replace it with a 54" diameter connecting pipe.
 - d. Re-route Basins 8 and 33 to the wastewater treatment plant through the Waubonsie Interceptor.
 - e. Implement and maintain programmed maintenance on critical areas comprised of overflows 1, 4 and all the siphons.
 - f. Sewer separation upstream of overflow numbers 4, 8, 22 and 25 to reduce runoff into the combined system. Additionally implement inflow-infiltration reduction strategies in basins 24, 25, 26, 28, 29, 30 and 36.
 - g. Eliminate overflow number 6 diverting all flows from tributary sub-basins into the Hazel Avenue Interceptor.
 - h. Raise weirs 6" on overflows 5, 22, and 23 to eliminate bypassing during small storms.
 - i. Perform sewer separation in a 60 acre tract associated with the Transportation center project.
2. Improvements identified in paragraph 1 above shall be completed by July 31, 1988, with the exception of:
 - a. 30-inch storm sewer along Plum Street in basins 24 and 25, which shall be completed by November 1, 1988.
 - b. Removing of storm inlets along Lake Street in Basin 29, which shall be completed by November 1, 1988.
3. The Aurora Sanitary District Treatment facility shall be operated in accordance with the following provisions:
 - a. All flows received at the treatment plant must be screened and metered.
 - b. All flows up to 74 million gallons per day ("MGD") must receive a minimum of primary clarification prior to and during any occurrence of bypassing.
 - c. All flows up to 68 MGD must receive full treatment prior to and during any occurrence of bypassing ahead of or following primary treatment units.

4. Aurora Sanitary District and the City of Aurora shall conduct performance evaluation and reporting of the improvements specified in this Order in accordance with the Plan of Study appended to and which is hereby made a part of this Order.
5. This grant of exception does not preclude the Agency from exercising its authority to require as a permit condition a CSO monitoring program sufficient to assess compliance with this exception and any other Board regulations and other controls, if needed, for compliance, including compliance with water quality standards.
6. This grant of exception is not to be construed as affecting the enforceability of any provisions of this exception, other Board regulations, or the Environmental Protection Act.

IT IS SO ORDERED.

I, Dorothy M. Gunn, Clerk of the Illinois Pollution Control Board, hereby certify that the above Opinion and Order was adopted on the 13th day of July, 1988, by a vote of 7-0.

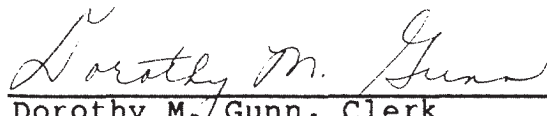

Dorothy M. Gunn, Clerk
Illinois Pollution Control Board

Appendix E
CSO Structure Drawings

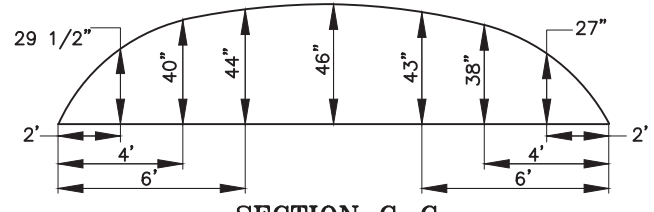

SECTION C-C

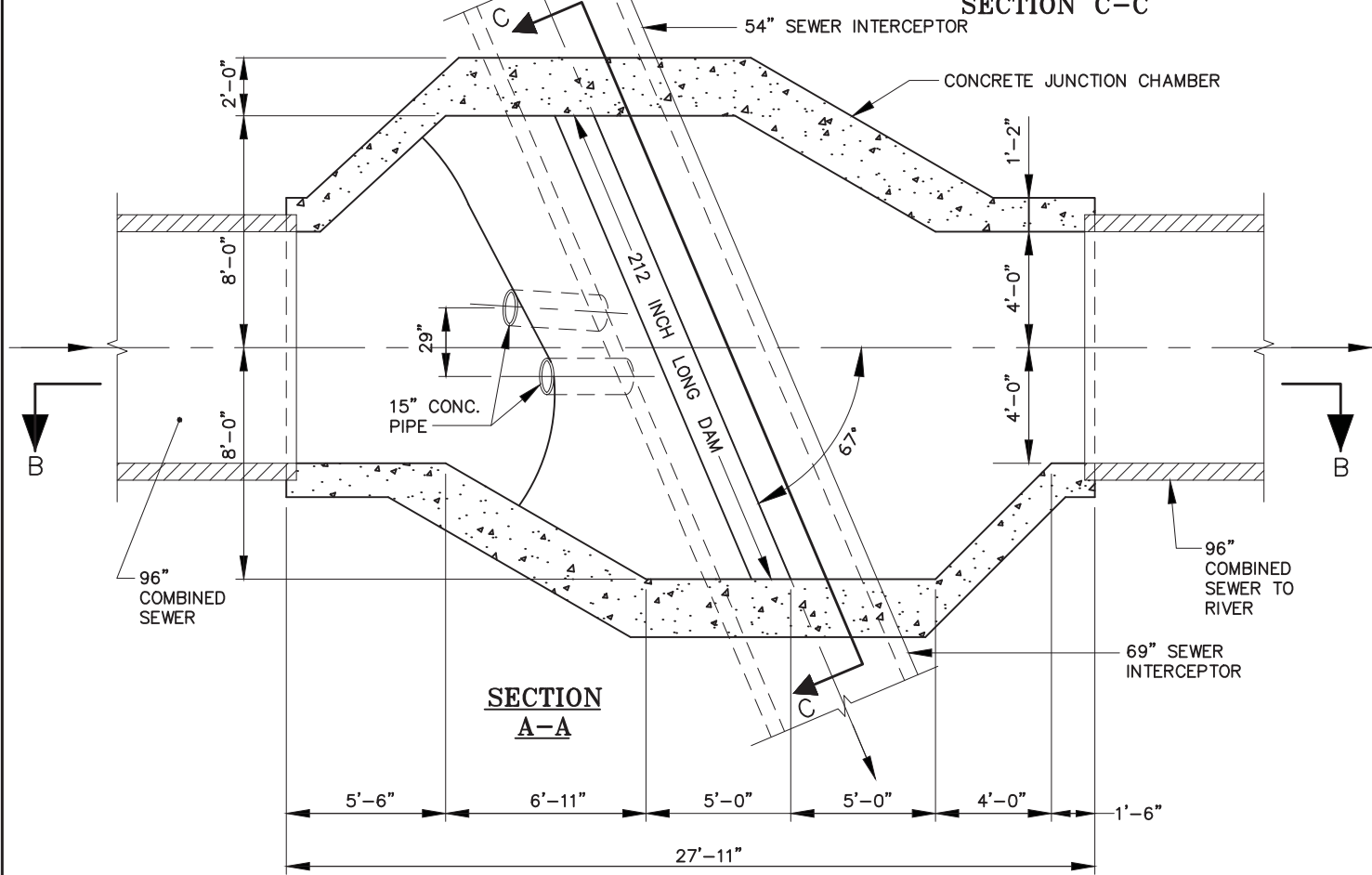

SECTION A-A

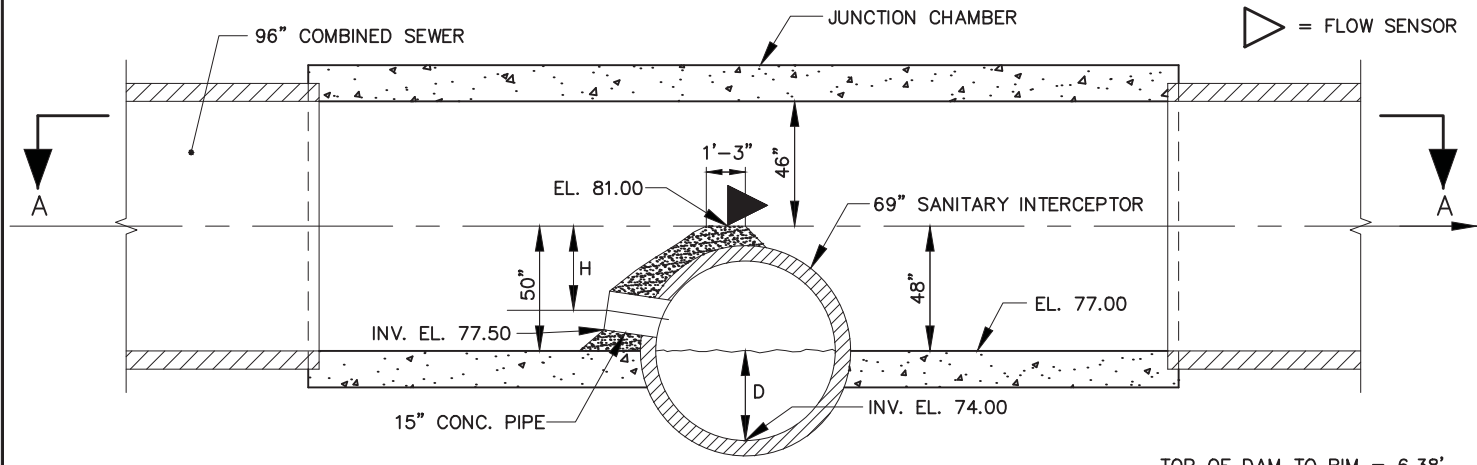

SECTION B-B

TOP OF DAM TO RIM = 6.38'
RIM = 625.31
DAM = 618.93

F:/ASD/06060-00/OVERFLOWS/JB-1



WALTER E. DEUCLER ASSOCIATES, INC.
Consulting Engineers - Aurora, Illinois

SHEET **1**
OF **1**

REVISIONS			
DESIGNED	JWF	APPROVED	JWF
DRAWN	JES	DATE	5/13/13
BOOK	203	JOB NUMBER	111/06060-00
SCALE			

CITY OF AURORA CSO 001
RATHBONE AVE.



▲ = FLOW SENSOR

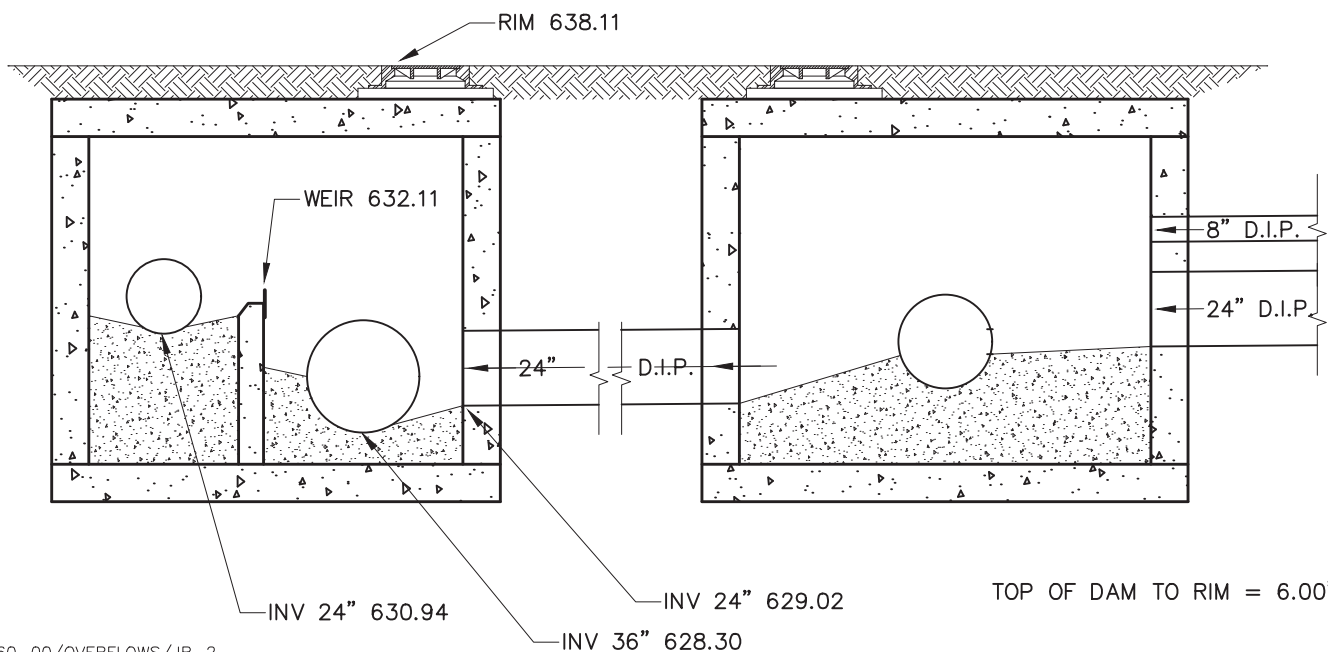
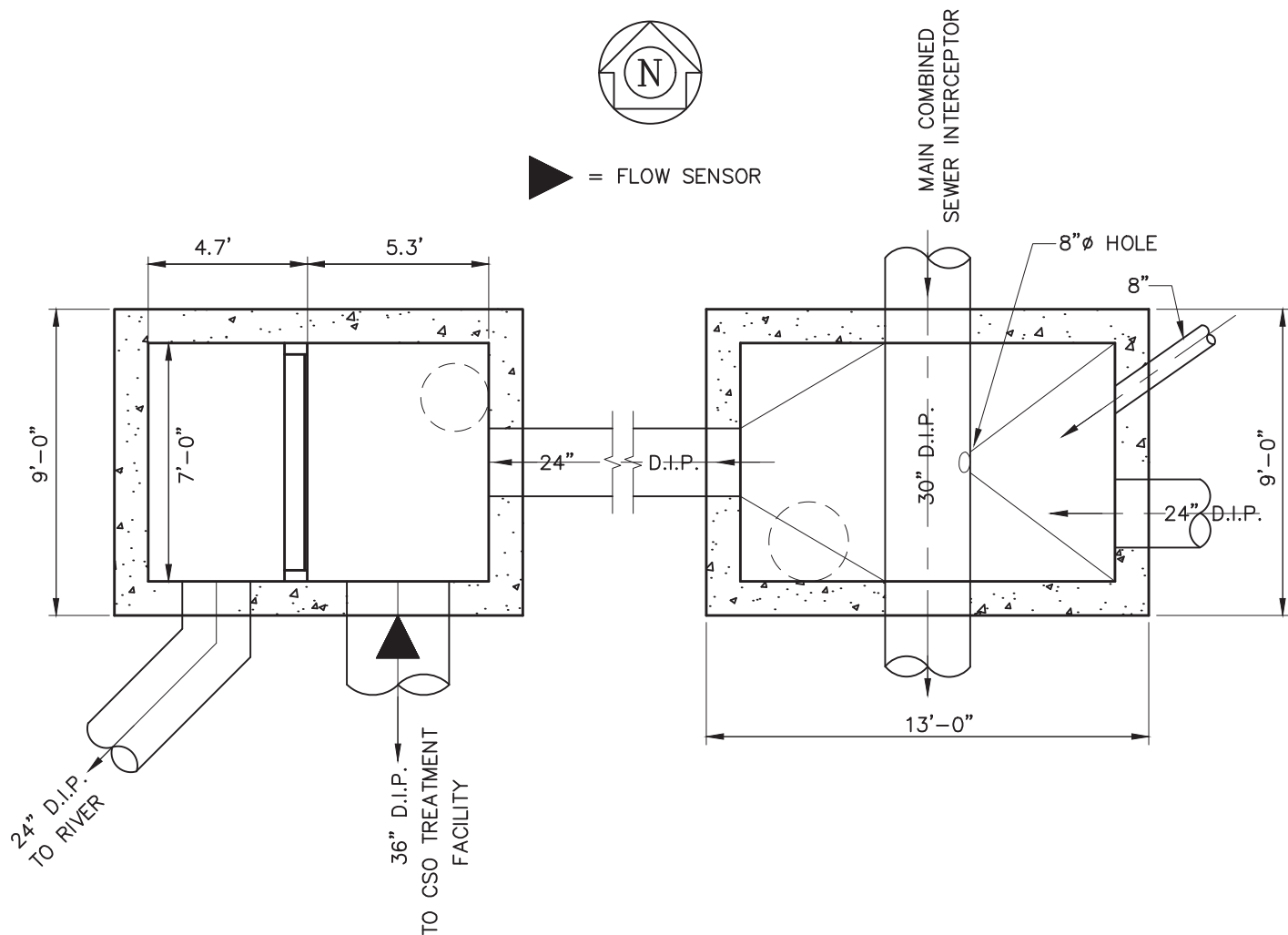

F:/ASD/06060-00/OVERFLOWS/JB-2



WALTER E. DEUCLER ASSOCIATES, INC.

Consulting Engineers - Aurora, Illinois

SHEET **1**
OF **1**

REVISIONS

DESIGNED	JWF	APPROVED	JWF	BOOK	203	JOB NUMBER	
DRAWN	JES	DATE	5/13/13	SCALE	1"=5'	111/06060-00	

**CITY OF AURORA CSO 002
EAST ILLINOIS AVE.**



▶ = FLOW SENSOR

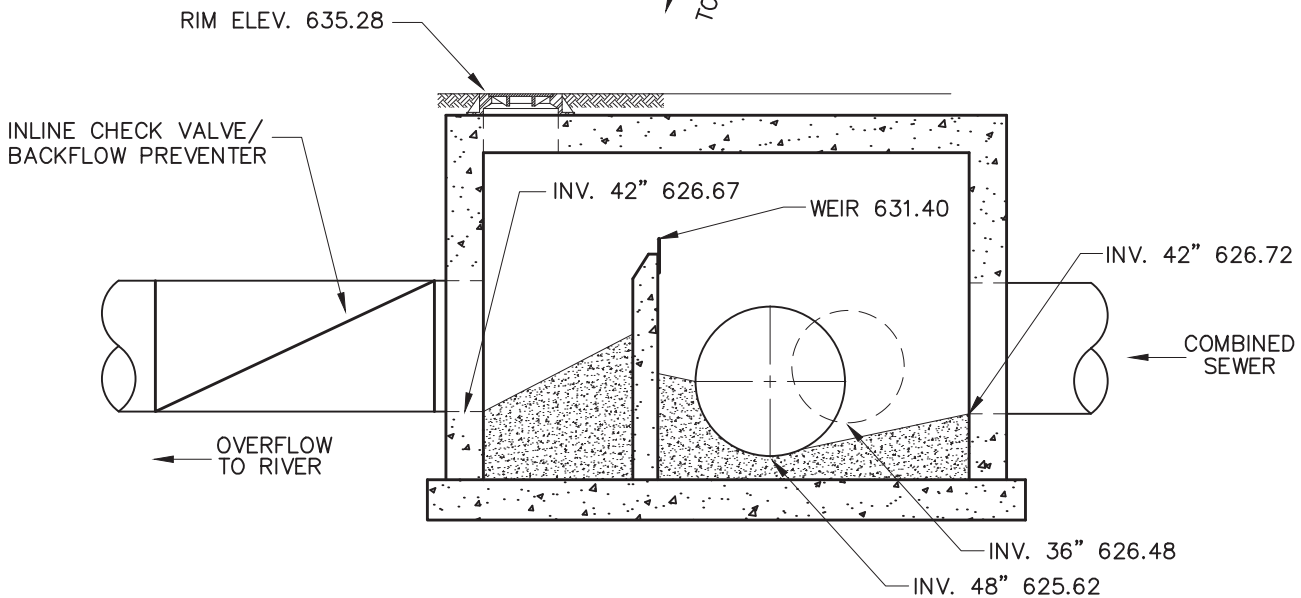
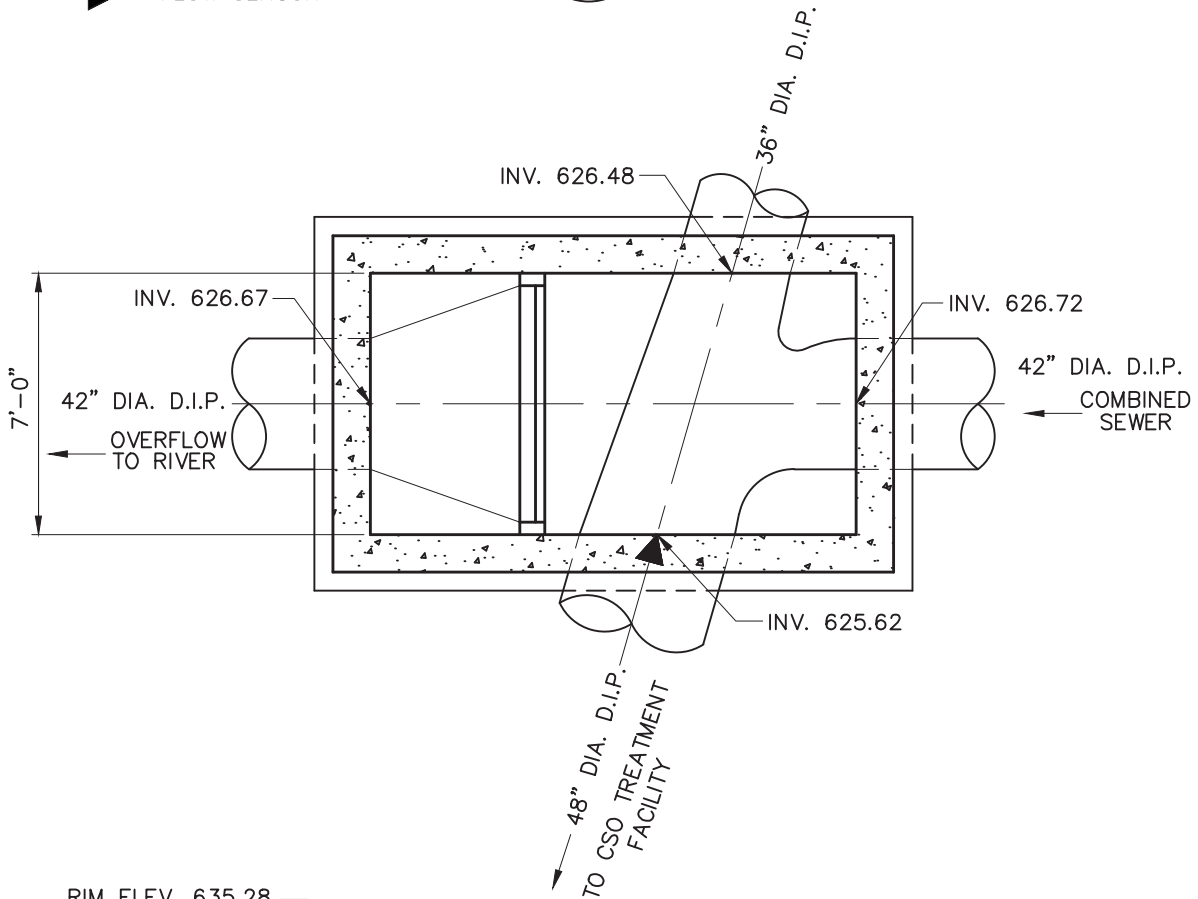

TOP OF DAM TO RIM = 3.88'

F:\ASD\06060-00\OVERFLOWS\OVF-3



WALTER E. DEUCLER ASSOCIATES, INC.

Consulting Engineers - Aurora, Illinois

SHEET	1
OF	1

REVISIONS
SHOW LOCATION OF BACKFLOW PREVENTION - 11/9/15

DESIGNED	JWF	APPROVED	JWF	BOOK	203	JOB NUMBER	
DRAWN	JES	DATE	5/13/13	SCALE	1"=5'		111/06060-00

**CITY OF AURORA CSO 003A
PIERCE ST.**

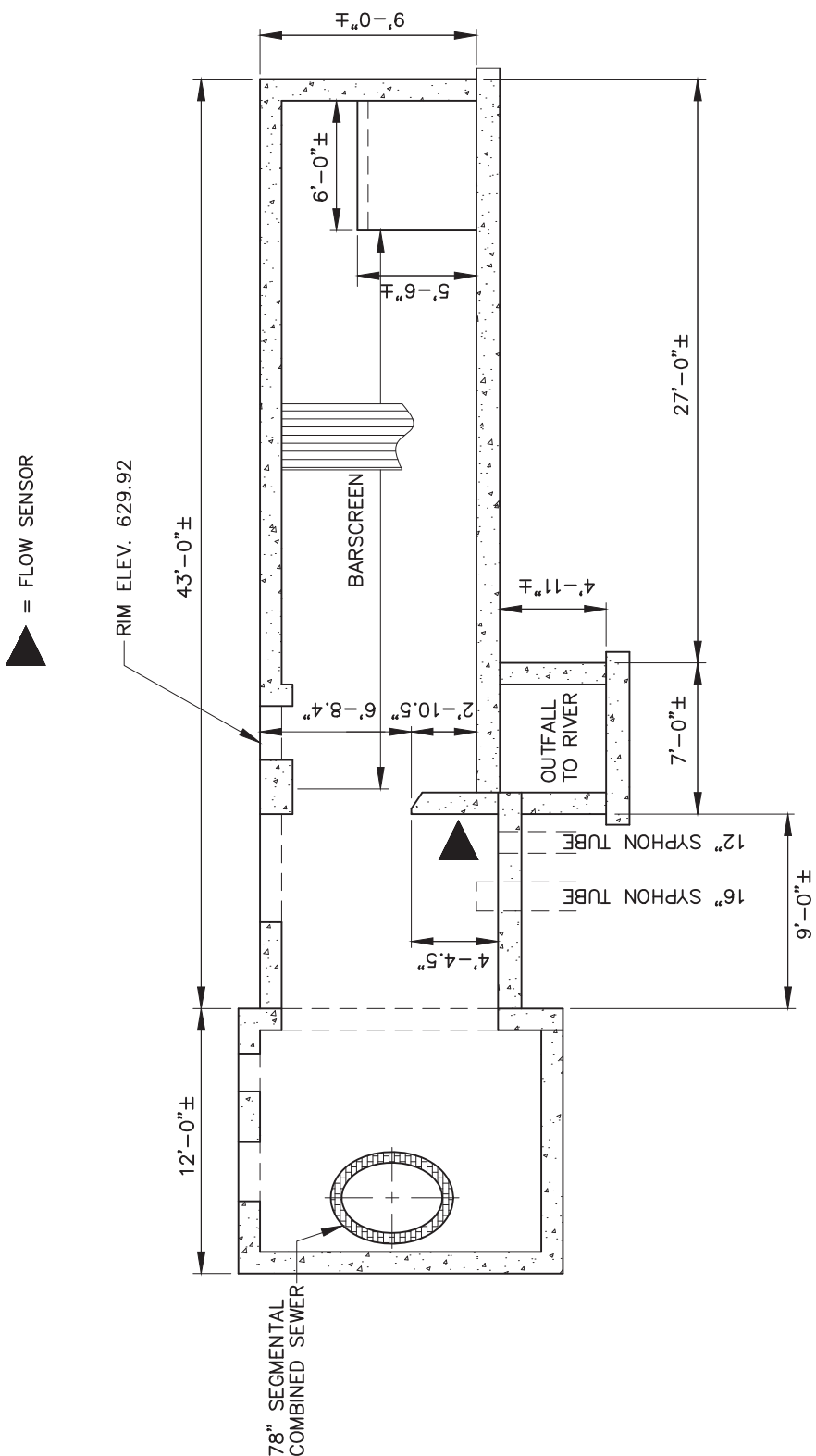

TOP OF WEIR ELEV. = 623.22

F:/ASD/06060-00/OVERFLOWS/OVF-4



WALTER E. DEUCLER ASSOCIATES, INC.
Consulting Engineers - Aurora, Illinois

SHEET **1**
 OF **1**

REVISIONS			
DESIGNED	JWF	APPROVED	JWF
DRAWN	JES	DATE	5/13/13
BOOK	203	SCALE	1"=3'
JOB NUMBER	111/06060-00		

CITY OF AURORA CSO 004
HAZEL AVE.

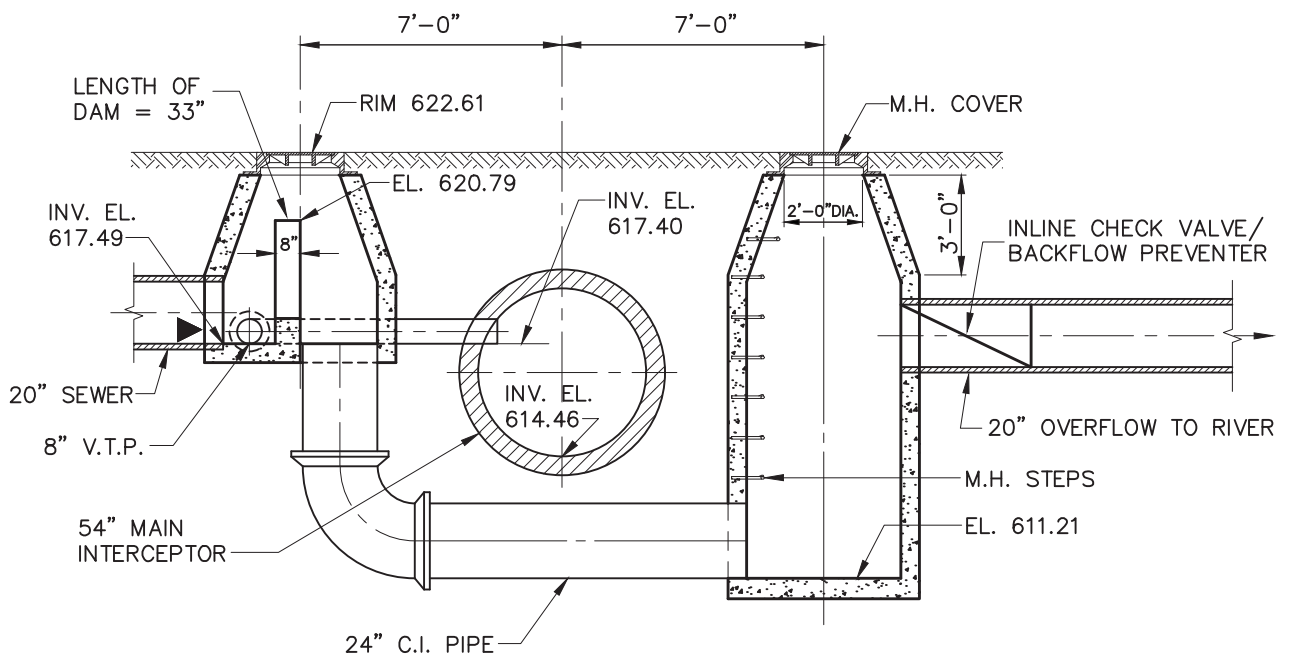
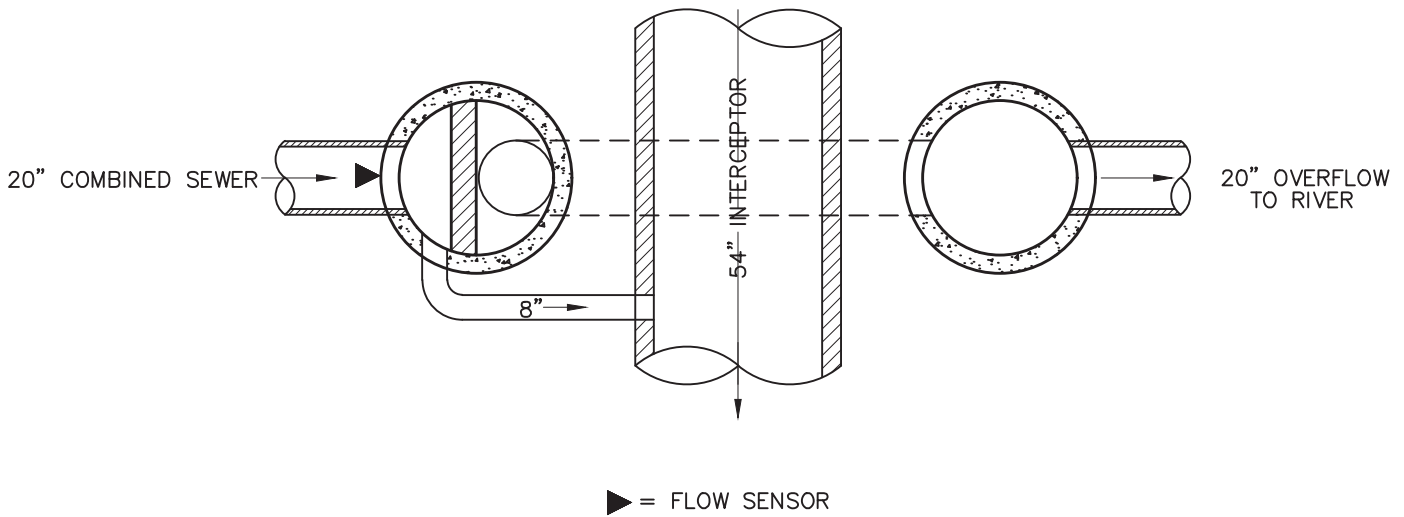

F:/ASD/06060-00/OVERFLOWS/JB-5



WALTER E. DEUCLER ASSOCIATES, INC.
Consulting Engineers - Aurora, Illinois

SHEET **1**
 OF **1**

REVISIONS			
SHOW LOCATION OF BACKFLOW PREVENTION - 11/9/15			
DESIGNED	JWF	APPROVED	JWF
DRAWN	JES	DATE	5/13/13
BOOK	203	JOB NUMBER	111/06060-00
SCALE	1"=5'		

**CITY OF AURORA CSO 005
 THIRD ST.**

DISCHARGE TO RIVER

INLINE CHECK VALVE/
BACKFLOW PREVENTER



▶ = FLOW SENSOR

72" DIA. OVERFLOW TO RIVER

54" DIA.
SEWER

OVERFLOW
DAM

INV. EL. 621.34

72" DIA.
COMBINED
SEWER

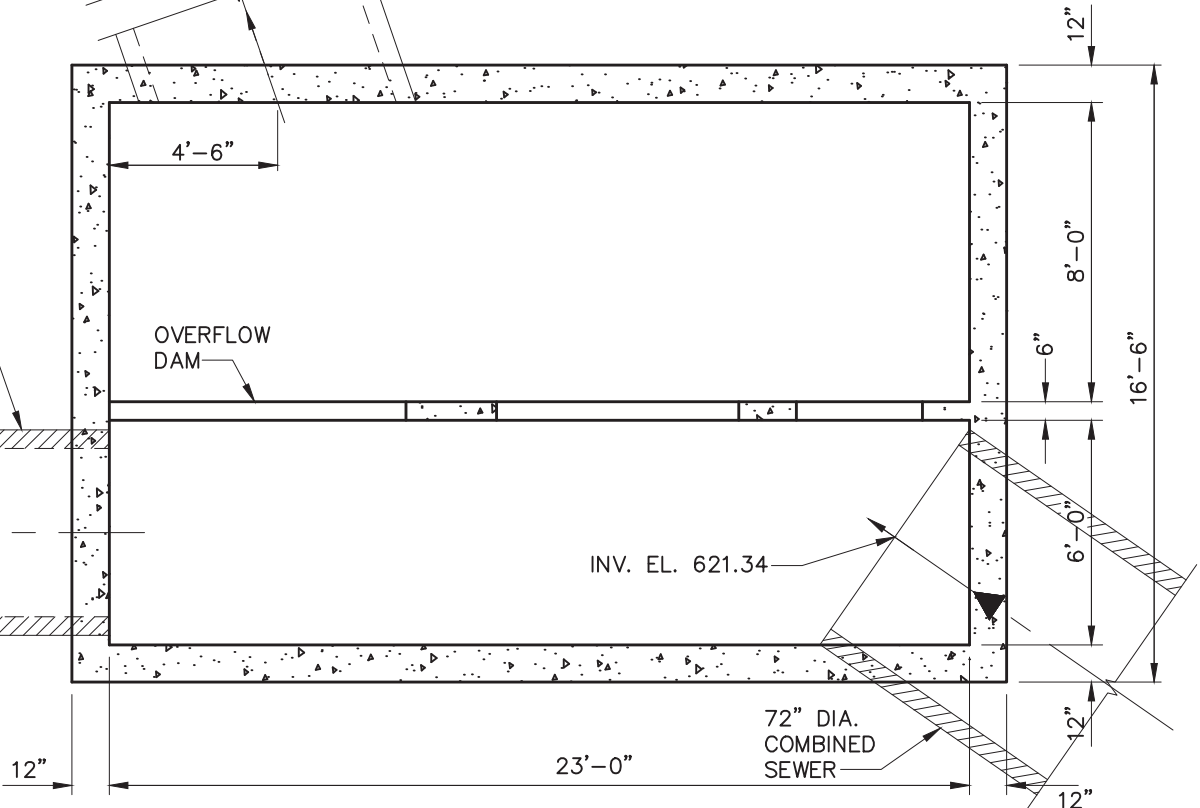

GRAVEL PARKING LOT

72" DIA. OVERFLOW TO RIVER
INV. EL. 621.39

OVERFLOW DAM
EL. 624.93

RIM = 637.38

54" DIA.
SEWER
INV. EL. 620.59

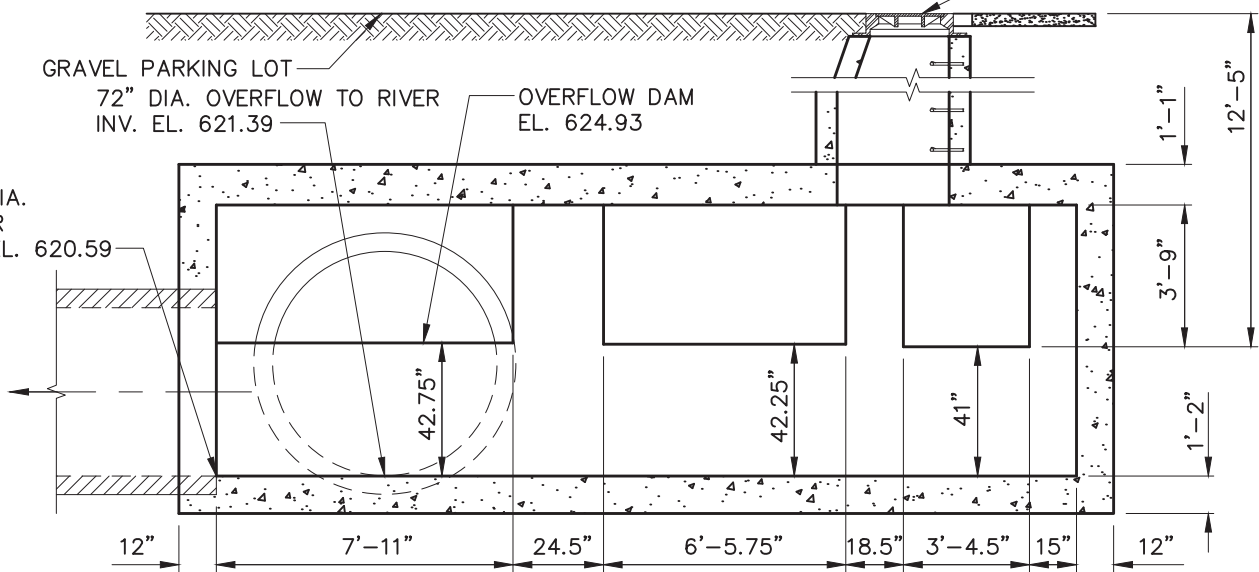

F:/ASD/06060-00/OVERFLOWS/OVF-8



WALTER E. DEUCLER ASSOCIATES, INC.

Consulting Engineers - Aurora, Illinois

SHEET **1**
OF **1**

REVISIONS				
SHOW LOCATION OF BACKFLOW PREVENTION - 11/9/15				
DESIGNED	JWF	APPROVED	JWF	BOOK XXX
DRAWN	JES	DATE	01/28/08	JOB NUMBER 111/06060-00
				SCALE 1"=5'

CITY OF AURORA CSO 008
EAST BENTON ST.

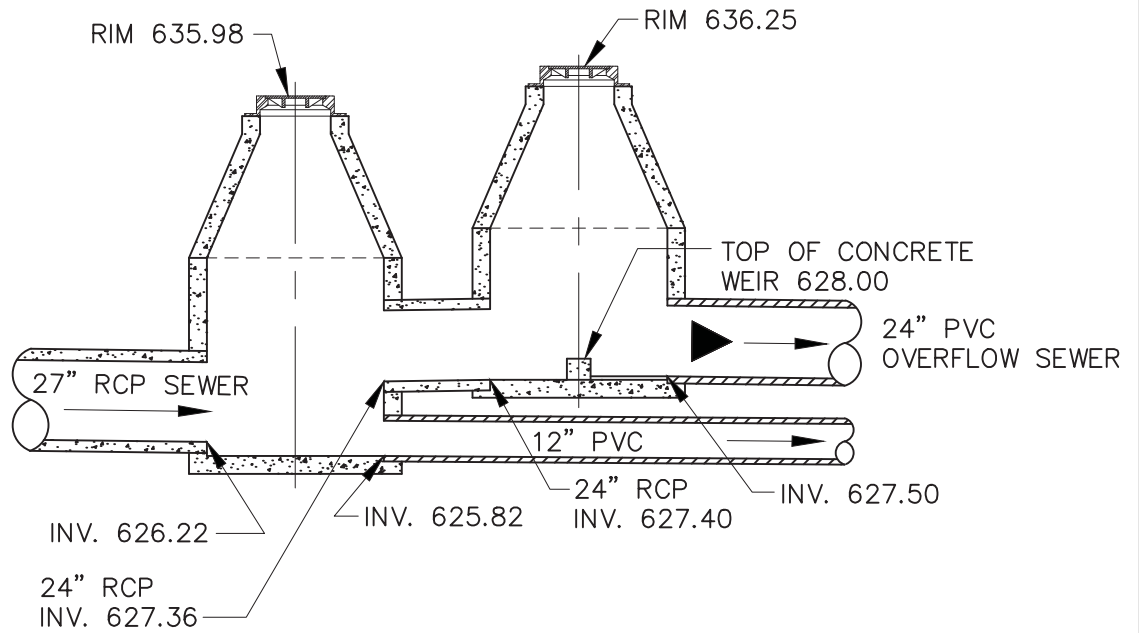
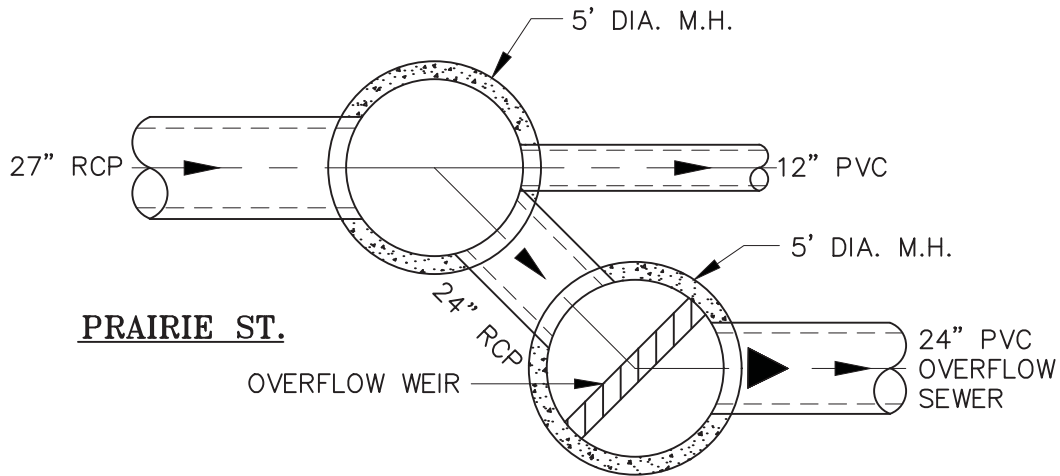

▶ = FLOW SENSOR

F:/ASD/06060-00/OVERFLOWS/OVF-10



WALTER E. DEUCLER ASSOCIATES, INC.
Consulting Engineers - Aurora, Illinois

SHEET **1**
 OF **1**

REVISIONS STRUCTURE RECONFIGURED - 6/11/14			
DESIGNED RDC	APPROVED JWF	BOOK FILE	JOB NUMBER
DRAWN JES	DATE 11/11/15	SCALE 1"=5'	111/06060-00

CITY OF AURORA CSO 010
FIRST ST.

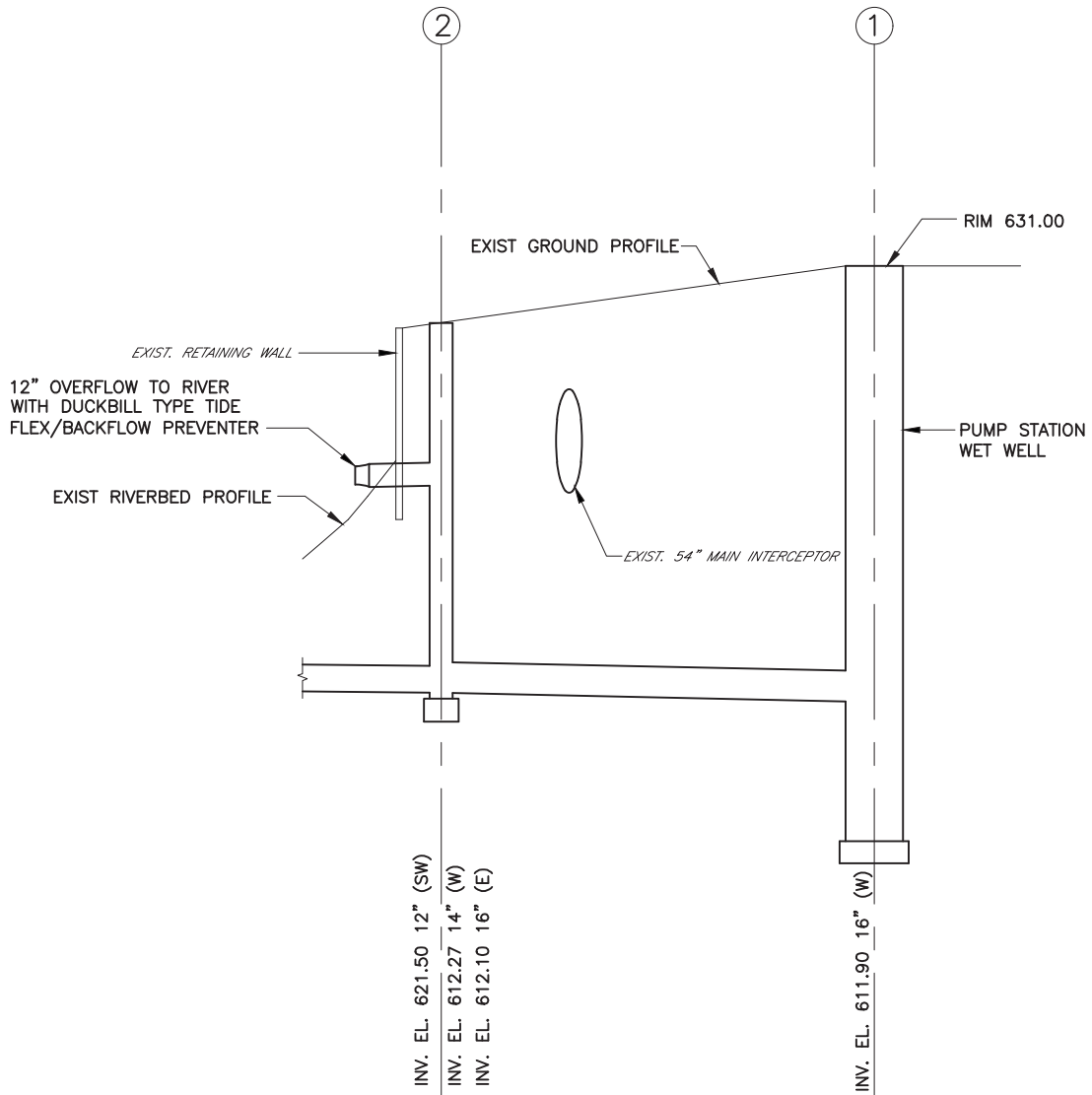

F:/ASD/06060-00/OVERFLOWS/11-9-15/OVF-16A



WALTER E. DEUCLER ASSOCIATES, INC.
Consulting Engineers - Aurora, Illinois

SHEET **1**
 OF **1**

REVISIONS

DESIGNED RDC	APPROVED JWF	BOOK 203	JOB NUMBER
DRAWN JES	DATE 5/17/16	SCALE 1"=2'	111/06060-00

CITY OF AURORA CSO 016A
CLARK ST.

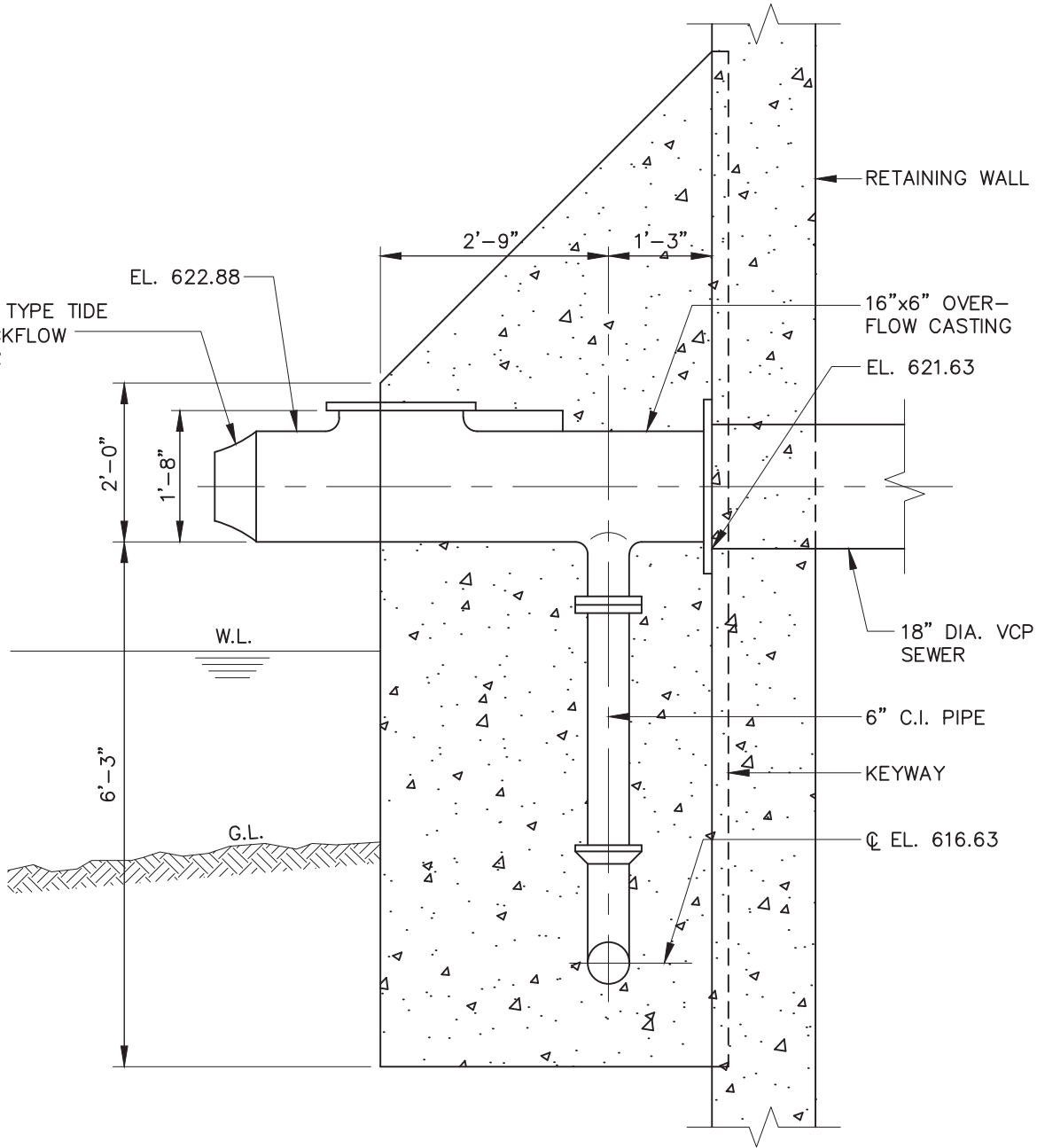

F:/ASD/06060-00/OVERFLOWS/OVF-17



WALTER E. DEUCLER ASSOCIATES, INC.

Consulting Engineers - Aurora, Illinois

SHEET	1
OF	1

REVISIONS
 CLARIFY LOCATION OF BACKFLOW PREVENTION - 11/9/15

DESIGNED	JWF	APPROVED	JWF	BOOK	203	JOB NUMBER	
DRAWN	JES	DATE	5/13/13	SCALE	1"=2'		111/06060-00

**CITY OF AURORA CSO 017
 STOLP AVE.**



▶ = FLOW SENSOR

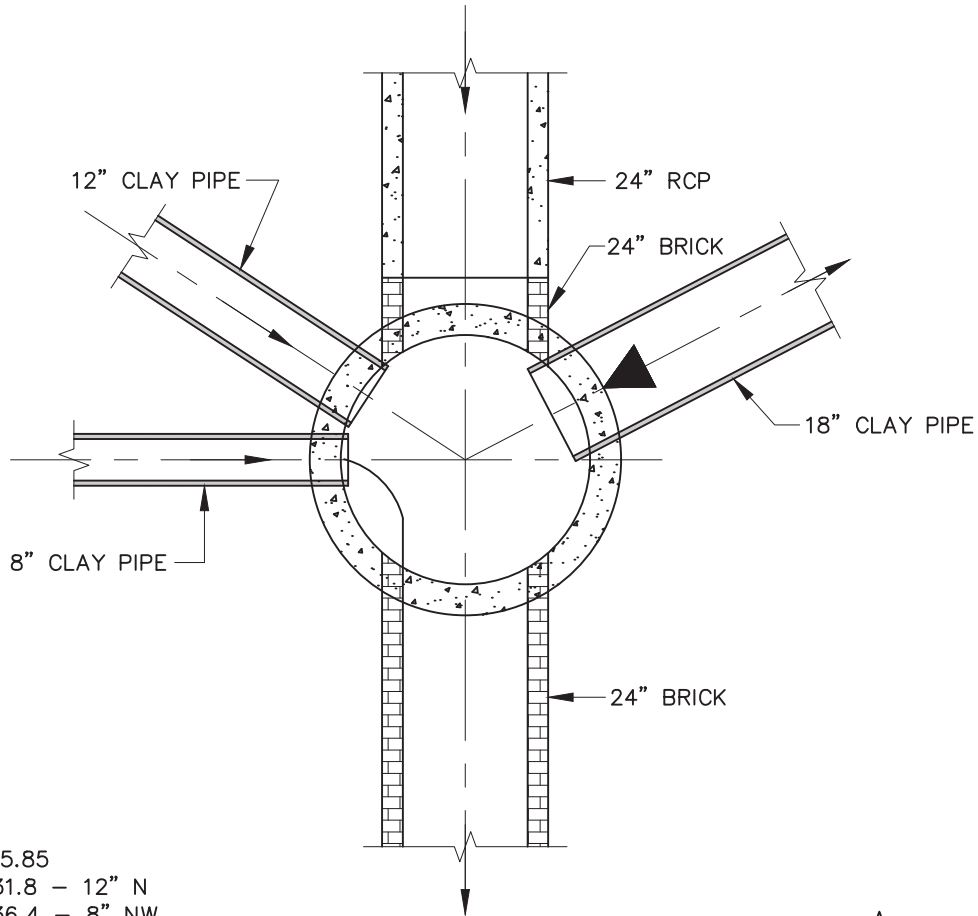

RIM 645.85
 INV. 631.8 - 12" N
 INV. 636.4 - 8" NW
 INV. 631.7 - 18" E
 INV. 630.8 - CL.

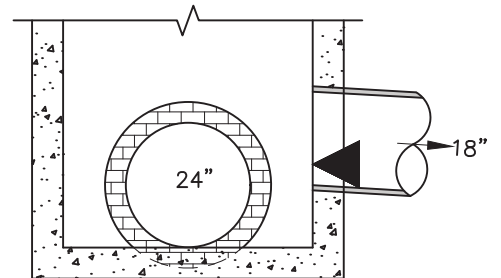

F:/ASD/06060-00/OVERFLOWS/COA - OVF-018



WALTER E. DEUCLER ASSOCIATES, INC.
Consulting Engineers - Aurora, Illinois

SHEET **1**
 OF **1**

REVISIONS

DESIGNED	JWF	APPROVED	JWF	BOOK	203	JOB NUMBER	
DRAWN	JES	DATE	5/13/13	SCALE	1"=3'		111/06060-00

CITY OF AURORA CSO 018
WEST GALENA BLVD.

LOCATION - CL. LAKE ST. AT WEST PARK AVE./ELM ST.

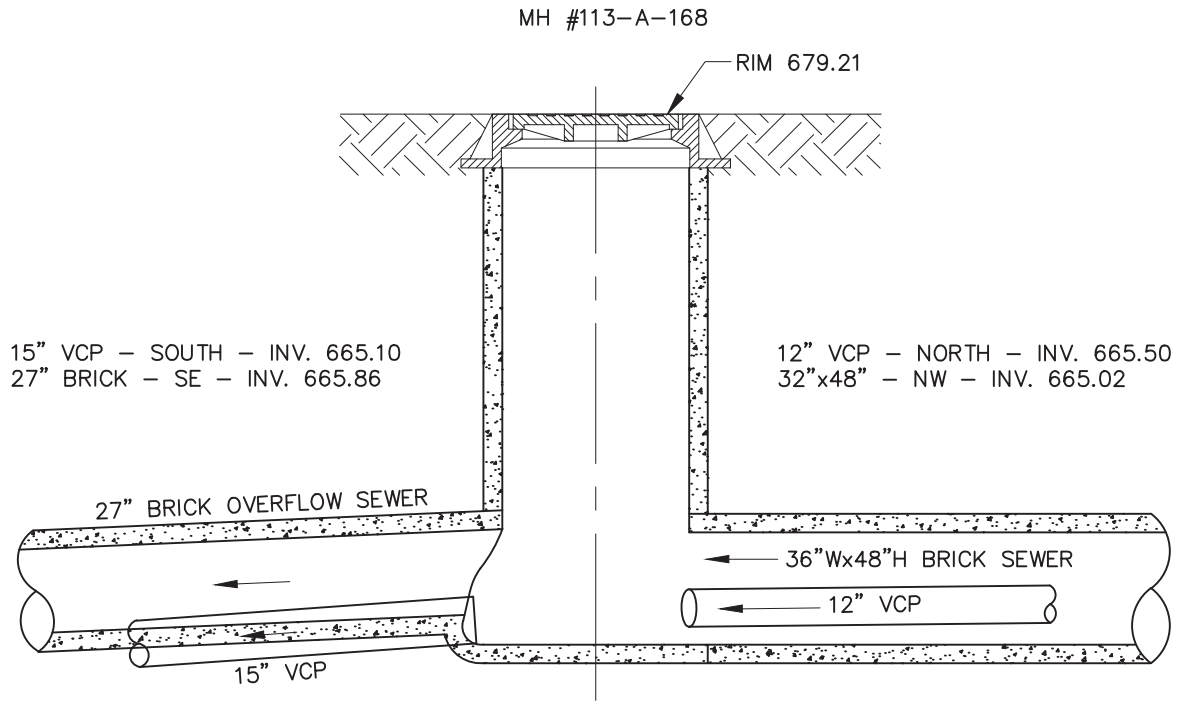
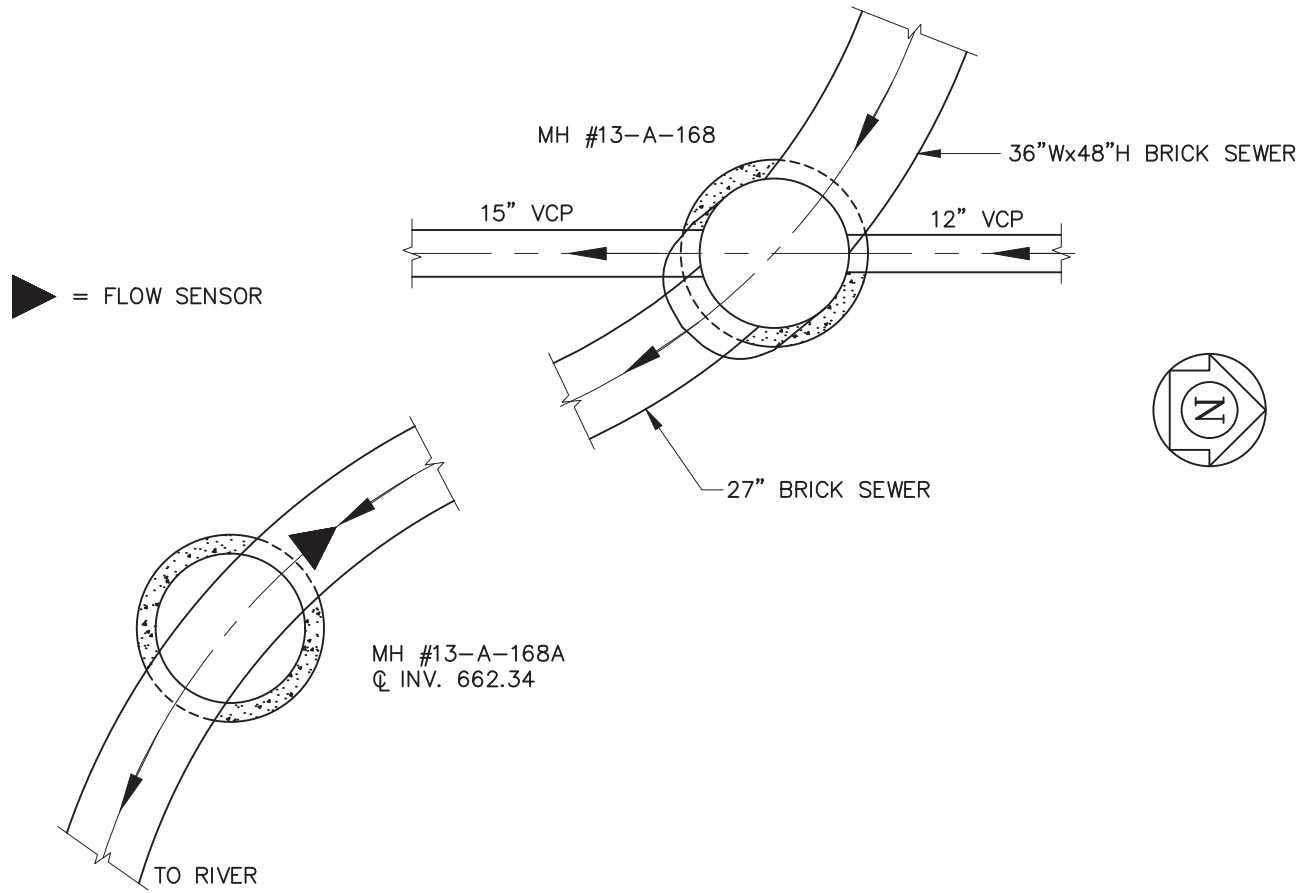

F:/AU/08023-00/OVF-21



WALTER E. DEUCHLER ASSOCIATES, INC.
Consulting Engineers - Aurora, Illinois

SHEET **1**
 OF **1**

REVISIONS			
DESIGNED RC	APPROVED RC	BOOK 203	JOB NUMBER
DRAWN JES	DATE 5/13/13	SCALE 1"=2'	155/08023-00

CITY OF AURORA CSO 021
ELM (WEST PARK AVE.)



▲ = FLOW SENSOR

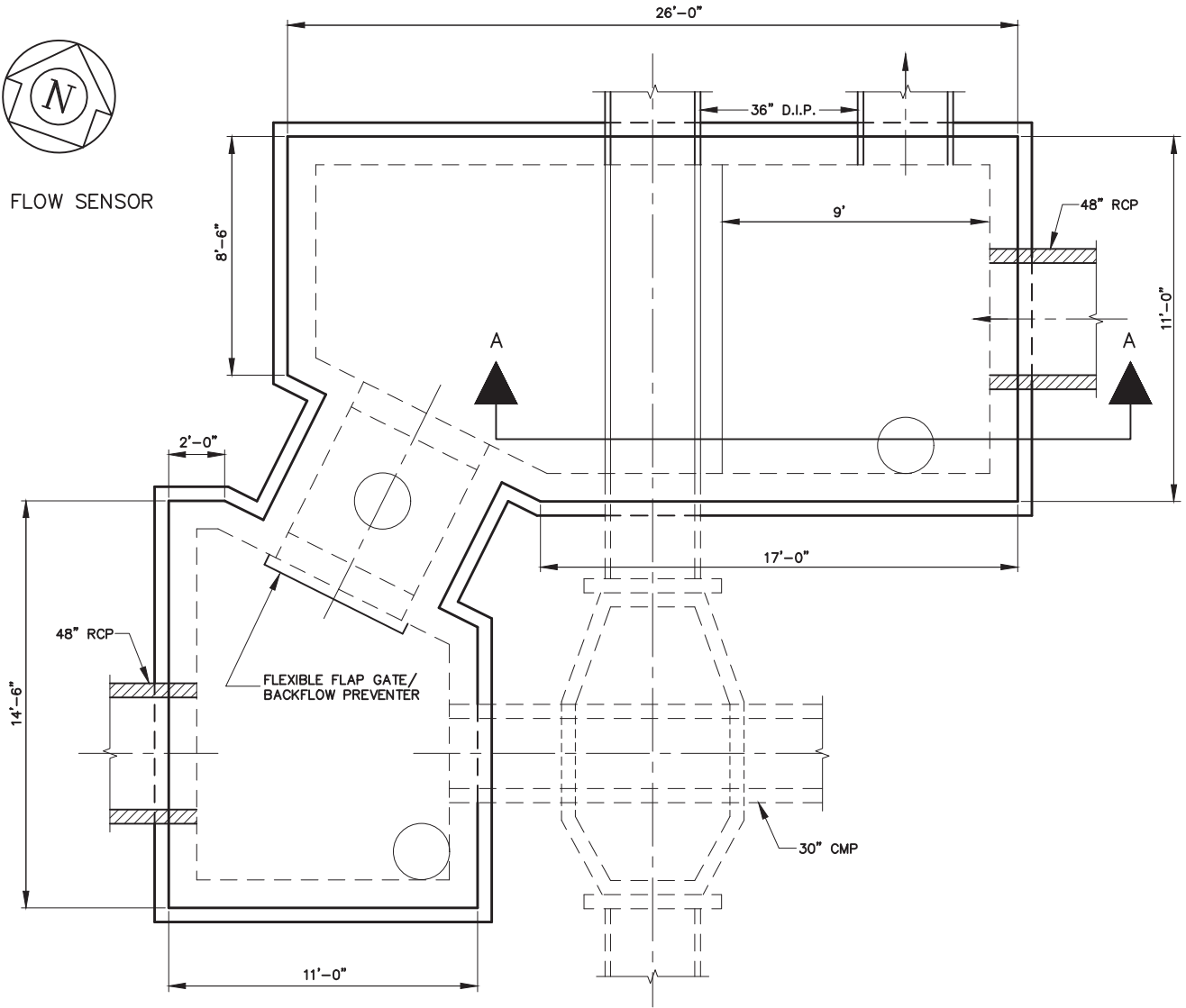

TOP OF WEIR ELEV. = 630.50

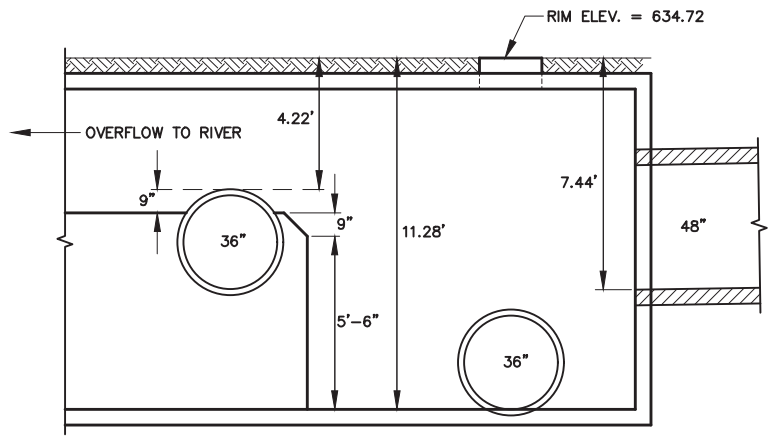

A - A

F:/ASD/06060-00/OVERFLOWS/OVF-22



WALTER E. DEUCHLER ASSOCIATES, INC.

Consulting Engineers - Aurora, Illinois

SHEET **1**
OF **1**

REVISIONS
CLARIFY LOCATION OF BACKFLOW PREVENTION - 11/9/15

DESIGNED	JWF	APPROVED	JWF	BOOK	203	JOB NUMBER	
DRAWN	JES	DATE	5/13/13	SCALE	1"=4'		111/06060-00

**CITY OF AURORA CSO 022
SUPERIOR ST.**



▷ = FLOW SENSOR

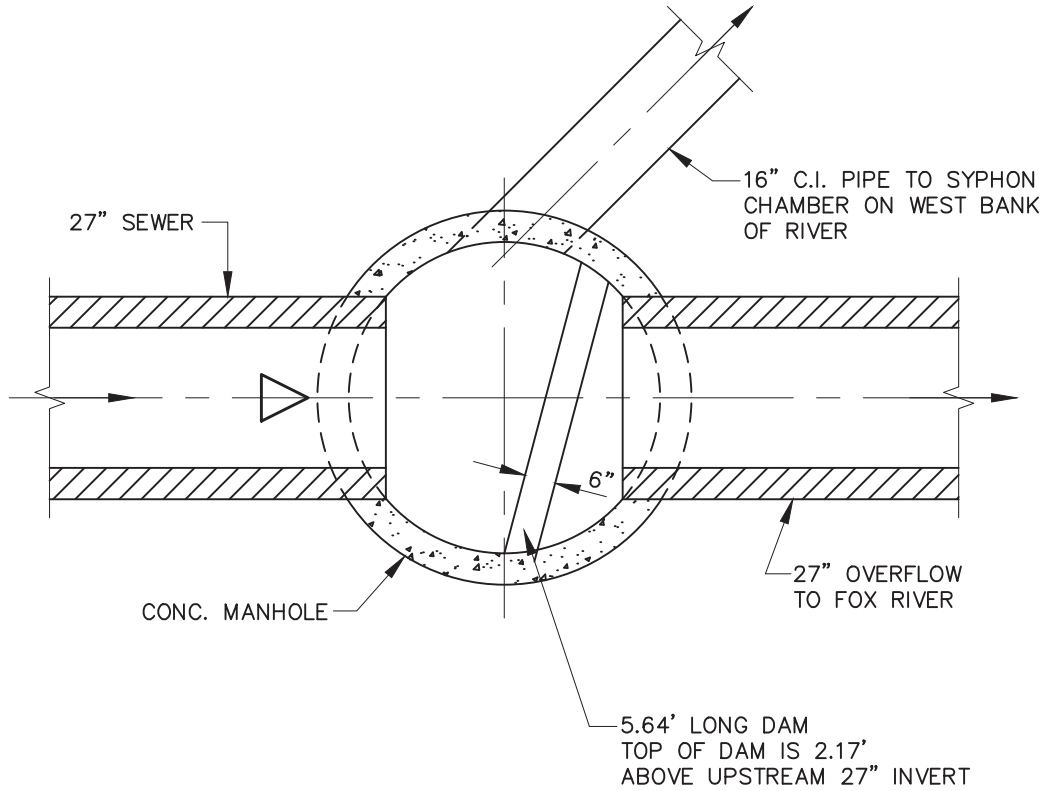

TOP OF DAM TO RIM = 3.75'
RIM ELEV. = 642.09
TOP OF DAM ELEV. = 638.34

F:/ASD/06060-00/OVERFLOWS/OVF-23



WALTER E. DEUCLER ASSOCIATES, INC.
Consulting Engineers - Aurora, Illinois

SHEET **1**
OF **1**

REVISIONS

DESIGNED JWF	APPROVED JWF	BOOK 203	JOB NUMBER
DRAWN JES	DATE 5/13/13	SCALE 1"=3'	111/06060-00

CITY OF AURORA CSO 023
WEST ILLINOIS AVE.

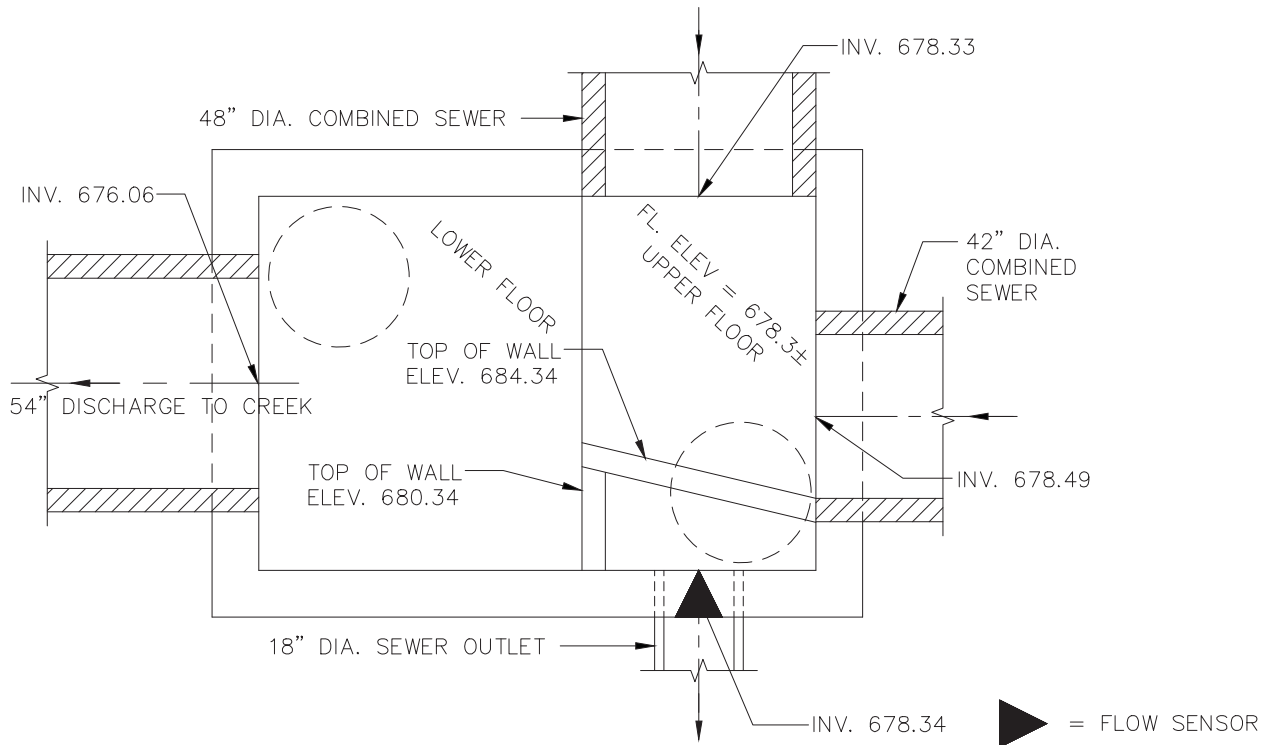

RIM ELEV. = 691.46
TOP OF DAM ELEV. = 680.34

F:/ASD/06060-00/OVERFLOWS/OVF-25



WALTER E. DEUCHLER ASSOCIATES, INC.

Consulting Engineers - Aurora, Illinois

SHEET **1**
OF **1**

REVISIONS 12/17/15 - RECONSTRUCTED OVF WEIR

DESIGNED RDC	APPROVED RDC	BOOK XXX	JOB NUMBER
DRAWN JES	DATE 11/4/15	SCALE 1"=4'	111/94061-03

CITY OF AURORA CSO 025
DEARBORN AVE. & TRASK ST.

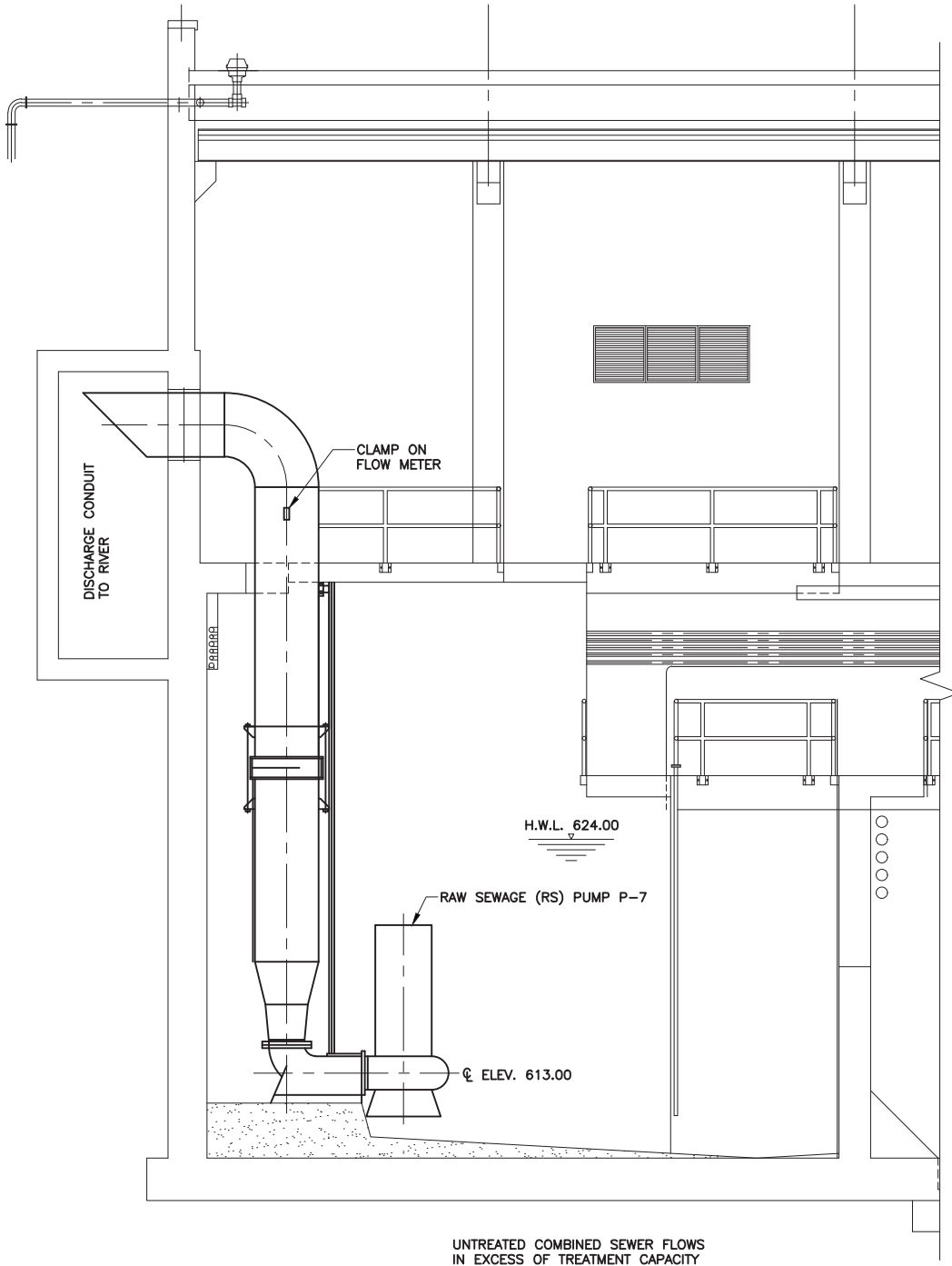

F:/ASD/06060-00/OVERFLOWS/OVF-27



WALTER E. DEUCHLER ASSOCIATES, INC.
Consulting Engineers - Aurora, Illinois

SHEET **1**
 OF **2**

REVISIONS

DESIGNED	RDC	APPROVED	JWF	BOOK	XXX	JOB NUMBER	
DRAWN	JES	DATE	5/17/16	SCALE	1"=4'	111/06060-00	

**CITY OF AURORA CSO 027
 CSO TREATMENT FACILITY**

FOX RIVER



DISCHARGE CONDUIT TO RIVER

48" INFLUENT COMBINED SEWER

36" INFLUENT COMBINED SEWER

UNTREATED COMBINED SEWER DISCHARGE IN EXCESS OF TREATMENT CAPACITY

TREATED COMBINED SEWER DISCHARGE

P-7

CHLORINE CONTACT TANK #1

CHLORINE CONTACT TANK #2

PRIMARY TANK #1

PRIMARY TANK #2

PRIMARY TANK #3

PRIMARY TANK #4

BROADWAY AVENUE

F:/ASD/06060-00/OVERFLOWS/OVF-27



WALTER E. DEUCHLER ASSOCIATES, INC.

Consulting Engineers - Aurora, Illinois

SHEET 2
OF 2

REVISIONS

DESIGNED RDC	APPROVED JWF	BOOK XXX	JOB NUMBER
DRAWN JES	DATE 5/17/16	SCALE 1"=4'	111/06060-00

CITY OF AURORA CSO 027
CSO TREATMENT FACILITY

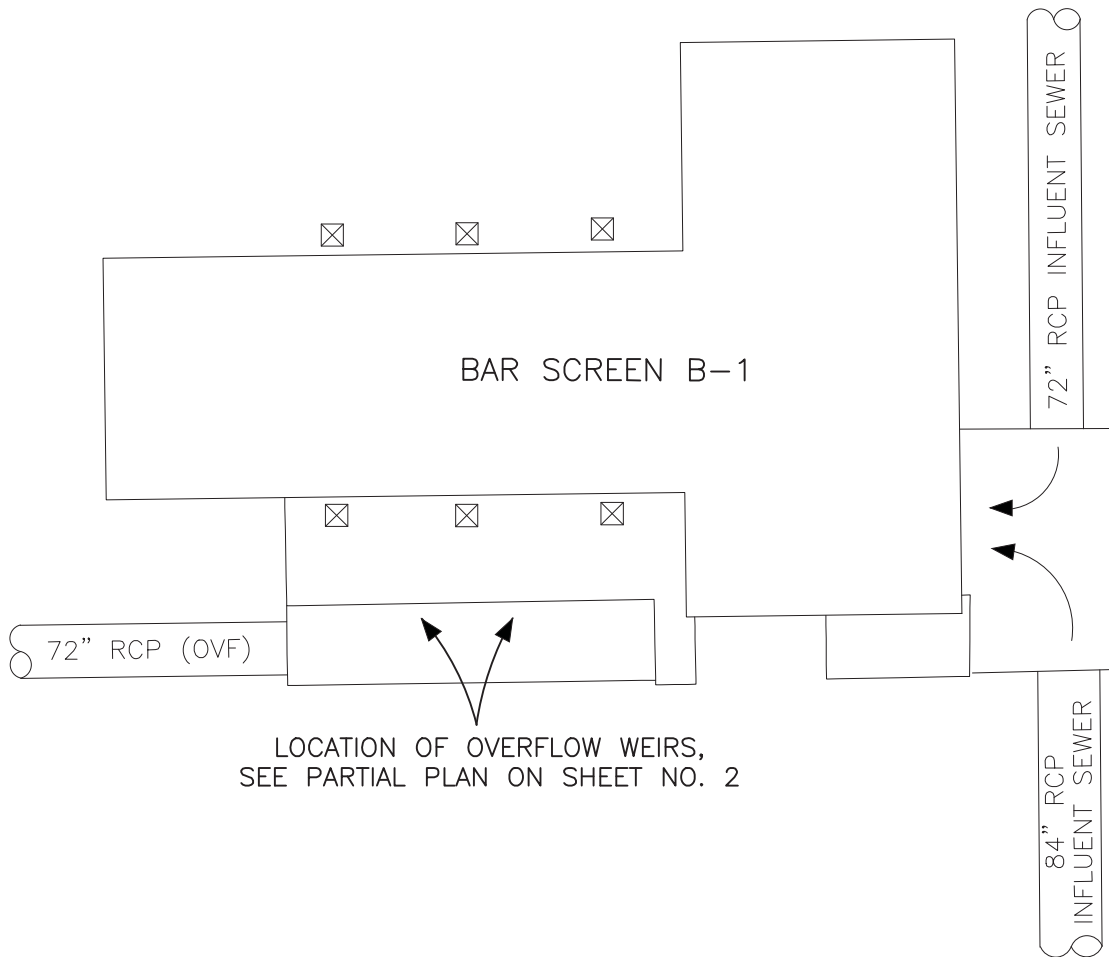

LOCATION OF OVERFLOW WEIRS,
SEE PARTIAL PLAN ON SHEET NO. 2



WALTER E. DEUCLER ASSOCIATES, INC.
Consulting Engineers — Aurora, Illinois

SHEET **1**
OF **2**

REVISIONS

DESIGNED RDC	APPROVED JWF	BOOK XXX	JOB NUMBER
DRAWN JES	DATE 5/23/16	SCALE 1"=20'	111/06060-00

FOX METRO W.R.D. CSO 002
WWTP HEADWORKS

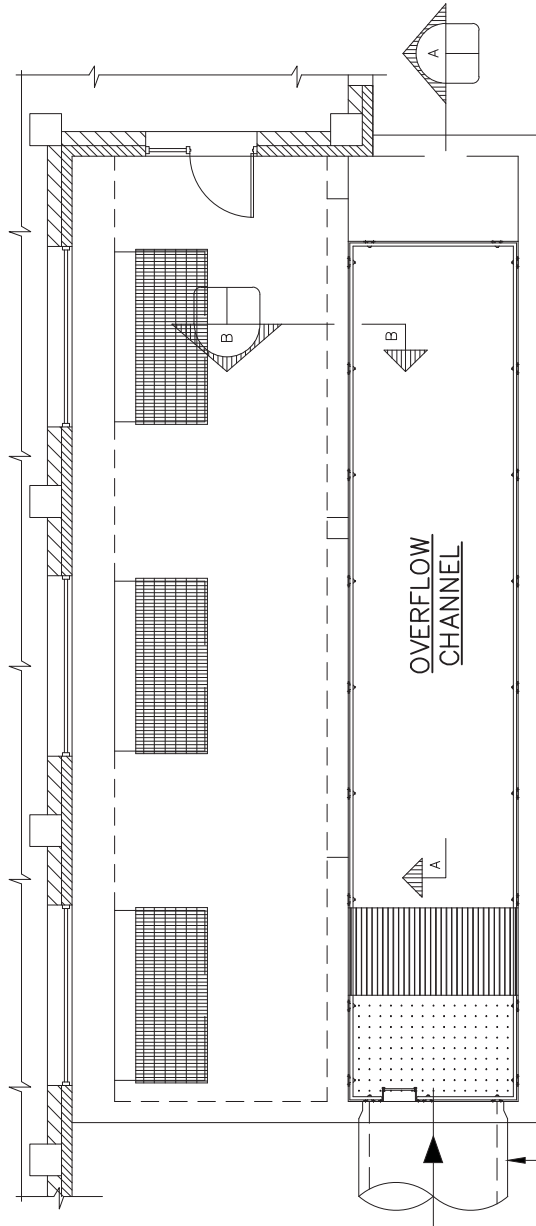

PARTIAL PLAN

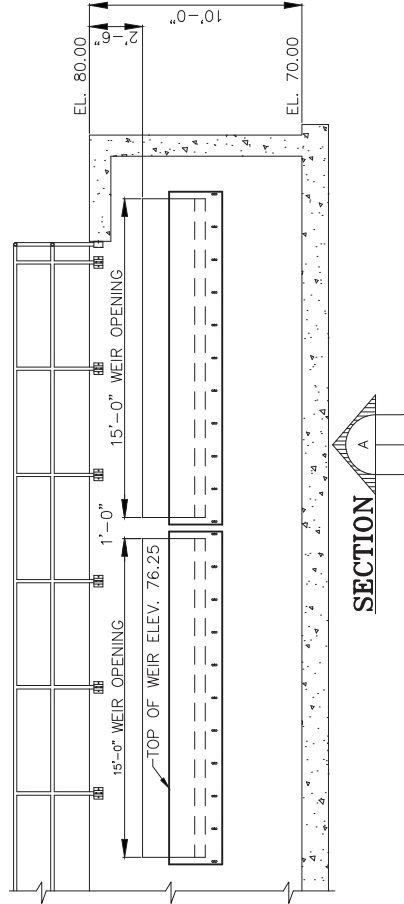
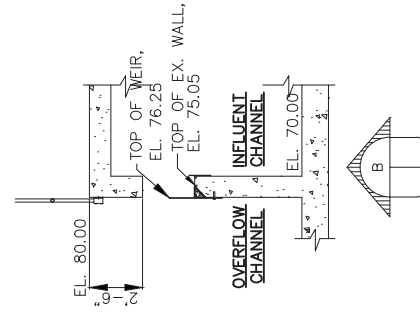

SECTION A-A

▲ = FLOW SENSOR

OVERFLOW CONDUIT TO RIVER



WALTER E. DEUCLER ASSOCIATES, INC.
Consulting Engineers — Aurora, Illinois

SHEET **2**
 OF **2**

REVISIONS

DESIGNED RDC	APPROVED JWF	BOOK XXX	JOB NUMBER
DRAWN JES	DATE 5/23/16	SCALE 1"=20'	111/06060-00

FOX METRO W.R.D. CSO 002
WWTP HEADWORKS

Appendix D

City of Aurora 2015 Yard Waste Collection Information

CITY OF AURORA'S YARD WASTE COLLECTION PROGRAMS

The City of Aurora encourages residents to look for alternatives to bagging yard waste for collection. Residents who wish to reduce or avoid yard waste costs should use mulching mowers, leaf shredders, or backyard compost piles. For those residents who wish to have their yard waste collected, the City of Aurora offers the following programs.

YARD WASTE COLLECTION

Yard waste collection begins the first Monday in April and ends the first Friday in December. Yard waste must be placed in a 30 gallon Kraft paper yard waste bag not to exceed 50 pounds and have a waste sticker attached. The stickers used for yard waste are the same as the stickers used for excess garbage. Yard waste mixed with trash or yard waste in a trash can or plastic bag will not be collected. Yard waste will be collected on the same day as your trash and must be at the curb by 6:00 a.m.

BUNDLED BRUSH

Unlimited bundled brush collection begins the first Monday in April and ends the first Friday in November. Branches and limbs 1/2 inch to 4 inches in diameter and 2 feet to 4 feet in length must be bundled. Each bundle must weigh less than 50 pounds. Bundled brush can be placed at the curb without a waste sticker. Brush less than 1/2 inch in diameter is considered yard waste and must be placed in a Kraft paper yard waste bag with a waste sticker attached.

SPRING AND FALL LEAF COLLECTION

Each year, Republic Services collects yard waste bags containing leaves for two weeks in the Spring and six weeks in the Fall without requiring a sticker. Exact dates will vary from year to year, depending on the weather. Dates will be announced each year in the Spring and Fall and posted on the City of Aurora website, www.aurora-il.org. Leaves must be placed in a 30 gallon Kraft paper yard waste bag and placed at the curb on your regularly scheduled garbage date.

CHRISTMAS TREES

Republic Services will collect Christmas trees during the first and second full weeks of January. Trees must be free of plastic bags, all decorations (including tinsel) and tree stands, and be placed at the curb on your normal collection day. Due to the wire used to form them, wreaths and garlands will not be collected as recycling and must be stickered as trash.

APPENDIX F

FMWRD Off-Plant Emergency and Response Plan



OFF PLANT

EMERGENCY AND RESPONSE PLAN

REVISED February 2016

FOX METRO WATER RECLAMATION DISTRICT

ON CALL PERSONNEL RESPONSIBILITIES

Mission Statement

Through leadership, innovation, and teamwork, provide quality wastewater treatment and maintain air standards to ensure a healthy environment for future generations at the best value for our community.

When we are on call there are times when we will be interacting with the public. It is each and everyone's responsibility to maintain a professional demeanor.

In this book you will find the emergency information and guides needed to perform your assigned tasks. Even though this Plan is designed to address the problems that may occur, there may be times when it doesn't. Please notify your supervisor so that he can help you make the proper response.

Never hesitate to call your supervisor in an emergency you can't address.

Never hesitate in calling in someone to assist when needed. Your personal safety should always be considered.

Memo

To: All On Call Personnel
From: Keith Zollers – Engineering and Field Supervisor
Date: 5/14/2015
Re: Call Out List Protocol

These are the guidelines for assuming/passing on the responsibilities of the person on call, to include any changes in the schedule.

1. The personnel assuming the week of on call will be expected to carry the on call iPad and Emergency Response Plan manual. It is this person's responsibility to check with the Foreman or Supervisor at the end of the working day Monday for any updates or current conditions to be aware of.
2. When the on call week is over, first thing Monday morning you will bring the on call iPad to the team room to be passed on to the next person in the rotation.
3. Personnel must be present on Monday to receive the on call duties. In the event of a Holiday, a plan will be discussed the week before on when the duties transfer.
4. No more than two-scheduled vacation days during your week of on call are allowed.
5. It is the person in conflicts responsibility to find a replacement or alternative prior to their week of on call.
6. Any changes in the schedule must be addressed with your respective foreman for approval so the proper people can be notified prior to the day of assuming the on call responsibilities.
7. Anyone who does not find their own replacement forfeits their turn until their next scheduled week.
8. Personnel on call have to be mentally and physically able to perform all duties required.

Personnel must also stay within a 50-mile radius of the district while on call.

On Call Procedure and Information

While on call, alarms from SCADA and back up complaints will call your work cell phone. Emergency JULIE tickets will be forwarded via e-mail to Don or Keith. If your assistance is needed to mark the JULIE ticket, then you will receive a call and the information from either Don or Keith.

SCADA will show up on caller I.D. as **630-859-9197**. The greeting is “this is SCADA alarm.” Follow the prompts. The three digit operator number is **004**. The four-digit pin number is **0616**.

Follow the prompts as you have been trained to retrieve the alarm data.

Sewer complaints that are left on the main office phone system after hours will show up on caller I.D. as **630-301-6888**. Upon answering there will be a woman’s voice saying this is the voice mailbox system (field Ops.). At this time, enter the I.D. number **9183**. Then wait for the prompt to enter the security code, **9911**. Follow the prompts to retrieve the sewer complaint. After retrieving the information, **you must archive or delete the message** to prevent the phone system from calling again.

For either SCADA or a Sewer Complaint, if you do not remember the I.D. numbers or security codes off hand, simply hang up, and call back as soon as you get the numbers from the On Call Book.

Confirmed Back-Up Procedure: Once it is determined that a Fox Metro owned sewer line is surcharged, addition staff will need to be called in to be able to dispatch the Jetter. Two people have to be present to jet a backed up line so the person fielding the complaint has to either stay till it is done or call in another union person to assist with the jetting.

Do Not call for clean-up of a basement without approval from Keith Zollers. In the event you are unsure, call for guidance.

Keith Zollers- Engineering and Field Supervisor: Cell 630-327-8926

Zac Bonesz- Field Ops Foreman: Cell 630-546-0293

Lift Stations and Field Operations Departments Call Out Numbers

Phone System-Backup Complaints.....630-301-6888
ID - #183, Password - 9911

SCADA- L.S. Alarms.....630 897-7066
Password – 004#

SCADA Backup Dialer.....630 897-7069
Alert Condition 1- PLC Fail, Alert Condition 2- Computer Fail. 555 to Acknowledge

Fox Metro Water Reclamation District Operations/Field Maint./Electrical Personnel

Name	Home	Mobile	Personal Cell
Matt Woodin	630-639-7502	630-327-8921	
Keith Zollers	630-466-8633	630-327-8926	
Zac Bonesz	630-917-3478	630-546-0293	
Don Davis		630-327-8919	
Mike Horton	630-896-2414	630-327-8922	
Andrew Orosco		630-327-8923	
Miroslaw Gusztyn	815-524-3494	630-327-8933	
Steve Galloway		630-947-9460	
Mark Furman		630-857-8076	
Matt Entile		630-774-9879	
Mike Petersen	630-553-8460	630-857-6083	630-639-7156
Derek King		630-450-2479	
David Penna		630-327-8931	630-608-9308
COLOR DESIGNATIONS	On Call Group	SCADA	Electrical

Building K – After Hours	630-892-4671
Building P – After Hours	630-892-4554
Reckinger Rd. Lift Station	630-851-4554
Farnsworth Lift Station	630-820-0301
Jefferson St. Lift Station	630-264-9482
North Aurora Lift Station	630-896-0372
Sugar Grove Lift Station	630-466-9828

Visu-Sewer 800-876-8478 Tom Woods – Visu-Sewer 708-595-6336

Reference – Emergency

Police Department	Emergency	Non-Emergency
Aurora	911	630-256-5000
North Aurora	911	630-897-8705
Kendall County & Ken Com	630-553-5856	630-553-6022
Paramedic Ambulance	911	
Oswego	630-554-3426	630-554-5936
Montgomery	911	630-897-8707
Sugar Grove	911	630-466-4526

<u>Fire Departments</u>	<u>Emergency</u>	<u>Non-Emergency</u>
Aurora	911	630-256-4000
Montgomery	911	630-897-0622
North Aurora	911	630-897-9698
Oswego	911 / 554-3241	630-553-5856 (Ken Com)
South Park	911	630-898-2121
Sugar Grove	911	630-466-4513

Reference for On Call Personnel

If you determine the problem or complaint is not ours, please use the numbers below:

City of Aurora

Water & Sewer Maintenance	256-3710
Main Pump	256-3600
Streets	256-3680
Water & Sewer (After Hours)	585-2845

Village of Montgomery

Water Department	896-1357
Garage	896-9241
After Hours - Police	897-8707
Engineering	896-1354

Mike Pubentz Supt. Of Public Works

Gary Byer, Water & Sewer

Village of Oswego

Public Works Department	554-3242
Police Dept. (After Hours)	554-3426
Mark Runion <i>(Supt. Of Public Works)</i>	330-3209
Jerry Weaver <i>(Utilities Coordinator)</i>	330-3208

Village of North Aurora

Garage	892-4680
Mike Glock <i>(Director of Public Works)</i>	606-3157
Village Hall	897-1457
Water (Ken Lopez)	897-8228 x229
H2O Field (Paul Young)	H: 897-6201 M: 710-6201
After Hours call Police Dept.	897-8705

Kendall County Highway Dept

Office	553-7616
Fran (Home)	553-0317
Andy (Home)	553-1522

Oswego Township

Oswego Township (Office)	554-8406
Gary	M: 675-7481 H: 554-1898

Village of Sugar Grove

Public Utilities Supervisor (Brad Merkel)	466-7508 x15 C: 461-4755
Chris Lemke	466-7508 x44 C: 461-4761
Joel Summerhill	466-7508 x40 C: 461-4765
Bryan Beach	466-7508 x43 C: 461-4757

Aurora Township

Aurora Township (Office)	892-0246
--------------------------	----------

Fox Metro

Building P (After Hours)	892-4708
Building K (After Hours)	892-4671
Field Operations (After Hours)	892-0616

Reference - Emergency

Electrical

Miroslaw Gusztyn	H: 815-524-3494	C: 630-327-8933
Mike Petersen	H: 630-639-7156	C: 630-857-6083
Mark Furnman	H:	C: 630-857-6076
Frank Marshall Electric	O: 630-892-2942	
Bill Marshall	H: 630-553-0038	
Bruce Anderson	H: 630-355-7521	
Steve McKennie	C: 630-631-2953	

Mechanic

Mike Horton (Field)	630-896-2414	C: 630-327-8922
Jeff Fulone (Plant)	630-327-6819	

Pumping - Rentals

Godwin Pumps	708-889-1560	
Bob Spatz		
Bob Spinner	815-464-5895	

Pumps & Tank Container Systems

Banker Tanks (24 Hours)	800-225-3712	
Rental Max	630-964-1850	

Portable Generators

Forces Inc. (24 hours)	630-369-4100	
Charles Equipment	630-864-6000	
Patton Power Systems	630-530-2200	

Other Rental Equipment

1st Place Rental	630-554-3155	
After Hours (Jim)	630-897-6418	

Lighting

McAllister Equipment	708-389-7700	
Forces Inc.	630-369-4100	

Utilities

ComEd	800-334-7661
ComEd	800-376-7693
ComEd (William West Account Rep.)	Cell 630-388-9753 Desk 630-723-2107
Nicor	888-642-6748
AT&T	800-252-1133

Emergency Electric Power Shut Downs

If you need an emergency power shut off by ComEd, please call 1-800-ESO-POWER. Be prepared to provide a pole number if possible. If you do not have a pole number, refer to the “**Lift Station Locations**” page in your call out book and provide that information. Dual power feed stations include, Farnsworth, North Aurora, Reckinger Road and the CSO Facility.

Lift Station Locations / ComEd & Nicor Information

Field Shop	Location:	1135 S. Lake St.
	ComEd Account #:	7989785049
	Nicor Account #:	55-53-88-9830 9
	Nicor Meter #:	4662187
Jefferson	Location:	110 Jefferson St., Montgomery 60538
	Description:	Jefferson St. & West bank of river
	Agency Responding:	Montgomery
	ComEd Account #:	0555006052
	ComEd Meter #:	097130346
	Transformer #:	462324H4
	Nicor Account #:	Can not be found
Farnsworth	Location:	620 N. Farnsworth Ave., Aurora 60505
	Geo Location:	0W 1S Fransworth 1S Bnrr -Aurora
	Agency Responding:	Aurora
	ComEd Account #:	7422779009
	ComEd Meter #:	141419602
	Transformer #:	462144L2
	Nicor Account #:	No Gas Service
Reckinger	Location:	1305 Reckinger Rd. Aurora 60505
	Description:	Reckinger Rd @ East Bank of Indian Creek
	Agency Responding:	Aurora
	ComEd Account #:	7587285002
	ComEd Meter #:	145030247
	Transformer #:	462114F9
	Nicor Account #:	37-50-71-1000 7
	Nicor Meter #:	3162208
Route 25	Location:	1175 S. Broadway Ave., Montgomery 60538
	Description:	In park on East bank of river
	Agency Responding:	Montgomery
	ComEd Account #:	1551077056
	ComEd Meter #:	141345327
	Transformer #:	462331F7
		No Natural Gas

Lift Station Locations / ComEd & Nicor Information

North Aurora	Location:	140 S. Lincolnway, North Aurora 60542
	Geo Location:	0N Fox River R1N Riverview - Aurora
	Agency Responding:	North Aurora
	ComEd Account #:	7919514003
	ComEd Meter #:	141608606
	Transformer #:	464044H4
	Nicor Account #:	69-80-71-1000 7
	Nicor Meter #:	2834153
Sugar Grove	Location:	41 W 356 Galena Rd., Sugar Grove
	Description:	South side of creek
	Agency Responding:	Sugar Grove
	ComEd Account #:	3545042058
	ComEd Meter #:	116732107
	Transformer #:	461152E7
	Nicor Account #:	50-08-40-1000 3
	Nicor Meter #:	3144169
Orchard Road	Location:	3305 Orchard Rd., Oswego
	Description:	West of bridge No. side of river
	Agency Responding:	Oswego
	ComEd Account #:	0517062001
	ComEd Meter #:	141467946
	Transformer #:	471241F2
	Nicor Account #:	83-17-50-1000 4
	Nicor Meter #:	3889375
Oswego	Location:	165 Harrison St., Oswego
	Agency Responding:	Oswego
	ComEd Account #:	2901111191
	ComEd Meter #:	092612874
	Transformer #:	472173K1
	Nicor Account #:	34-47-20-1000 7
	Nicor Meter #:	4477155
Morgan Creek	Location:	0 N Collins 1 W Grove, Oswego Twsp.
	Agency Responding:	Oswego
	ComEd Account #:	0788316003
	ComEd Meter #:	141682752
	Transformer #:	4772291E4
		No Natural Gas

Lift Station Locations / ComEd & Nicor Information

CSO

Location:	400 N. Broadway, Aurora 60505-2643
Telephone:	896-2064
Agency Responding:	Aurora
ComEd Account #:	1708129098
ComEd Meter #:	093725909
Transformer #:	462222H6
Nicor Account #:	20-37-30-1000 6
Nicor Meter #:	3358179

North Avenue

Location:	305 S River Street, Aurora 60506
Agency Responding:	Aurora
ComEd Account #:	5162136017
ComEd Meter #:	141177906
Transformer #:	462214M6
Feeder #	W107
Nicor Account #:	78-79-22-5695 6
Nicor Meter #:	2792830

Illinois Avenue

Location:	827 Orchard Avenue, Aurora 60506
Agency Responding:	Aurora
ComEd Account #:	0400143008
ComEd Meter #:	141379508
Transformer #:	462153A2
Feeder #	W5612
Nicor Account #:	23-47-24-3714 6
Nicor Meter #:	4438889

**Hazel Bar
Screen**

Location:	727 S Broadway Avenue, Aurora 60506
Agency Responding:	Aurora
ComEd Account #:	1183022014
ComEd Meter #:	115293858
Transformer #:	462284D4
Feeder #	W0607
Nicor Account #:	No Natural Gas
Nicor Meter #:	

**For power outages, please tell dispatch to enter S.B.T.
(Search by Transformer). Then you can confirm address after
you give the appropriate transformer number from this list.**

Fox Metro After Hours Alarm Response Guide

Condition		
ALARM	High / Low Flow or N/A	RESPONSE
Intrusion / Security	N/A	Call the non-emergency police number and meet them at the station. If a bad sensor is the problem follow the instructions for bypassing a sensor.
Fire / Smoke	N/A	Go to the station and check it out. The CSO is the only one that goes to the fire department. Call the fire department ASAP, if there is a fire.
Pump Failure / VFD Fault	High	Write down any error codes first. Reset & restart the pump. If the problem persist call the appropriate person in to repair the problem
Pump Failure / VFD Fault	Low	Verify condition at station, call electrician as needed.
Generator Run / Natural Gas Fueled	N/A	Make sure the station is powered up and the equipment is running and/or ready.
Generator Run / Diesel Fueled (Morgan & Orchard)	N/A	If the generator runs for more than 8 hours check the fuel level. If low (1/2 tank or less) call Feece Oil; (Mike Feece) 630-879-1911. If the generator keeps running you will have to keep it fueled until normal working hours.
Generator / All Other Alarms	N/A	Go to the station and assess the situation. Reset any alarms and restart. If the generator still fails and ComEd power is missing call a Fox Metro supervisor ASAP.
Power Fail	N/A	If the power is not restored after 10 minutes go to the station and assess the problem. If the power can not be restored call a Fox Metro supervisor ASAP.
Wet Well High Level	High / Low	Go to lift station and make sure all the pumps are pumping. Call in the appropriate person if problems are found. If this occurs during a storm event and flows are high, all we can do is make sure the equipment is working to it's capacity

Fox Metro After Hours Alarm Response Guide

Condition		
ALARM	High / Low Flow or N/A	RESPONSE
Wet Well Low Level	High / Low	Log on to SCADA and make sure the pumps are not stuck in hand. A bad level transducer or a stuck float can cause this. Go to the station and assess the problem.
Transducer Failure	High / Low	You must go directly to the station and check or switch to the backup system. Verify proper operation of the backup system. (A typical result of failure is a zero wet well level indication which is false) <i>This will result in the pumps not running.</i>
Low Temperature In Station	N/A	If it is winter time and the temperature is low enough to freeze the water lines, Go to the station and try to reset the heater. If this does not work call the appropriate person in to make repairs. Put a portable heater in the station until repair is complete.
Dry Well High Temp	N/A	Go to the station and assess the situation. Thermostats are set high enough to compensate for summer weather. This could be caused by a fire.
Exhaust / Supply Fan Failure	N/A	Acknowledge the alarm. Unless someone is working at the station, repair can be done during normal working hours.
CSO On Line	This Facility Only Runs When Flows Are High	Log on to SCADA and make sure all the equipment is working properly. If problems are noticed go to the CSO and assess any problem and respond accordingly.
CSO Tank 4 Full	This Facility Only Runs When Flows Are High	When this alarm occurs tank 5 will be filling. Be ready to go to the station If the rain event continues.
Chlorine Contact Tank Full	This Facility Only Runs When Flows Are High	You <u>MUST GO</u> to the CSO and take water samples . Follow the CSO Sampling Guide located at the station. Samples have to be taken every 24 hours when the CSO is discharging to the river.

Fox Metro After Hours Alarm Response Guide

Condition		
ALARM	High / Low Flow or N/A	RESPONSE
CSO De-Chlorination Start	This Facility Only Runs When Flows Are High	This alarm occurs when the de-chlorination pump(s) start(s) and the chlorine contact tank is full. It will occur intermittently as the wet well fills and empties.
CSO ON LINE ALARM KEEPS COMING ON	N / A	This alarm is coming on and off usually because the rain event is over and the grit tank levels are at a point where the float is bouncing just enough to keep getting the alarm. The grit tank level needs to be lowered to make this alarm go away. This can be accomplished by turning on the grit pumps (you will have to turn them back to auto when the level is low enough), Opening the hole from the grit tank to the wet well, or opening one of the grit tank drain valves.
Communication Failure (Comm Fail 1)	N / A	If SCADA calls with a Comm. fail, monitor the alarm for 1 Hour. If the alarm continues you must go to the station and investigate. In the event of heavy rains be aware of any Comm. Failures. Comm. Fails will not reset with a pump running. You will not get any alarms from a station with communication problems.
Communication Failure (Comm Fail 2)		This alarm only calls the supervisor. This alarm will appear on the computer alarm screen. (Do Not Acknowledge It) This is a 2 hour notification of Comm. Fail for instrumentation.
120 Volt Power Fail	N / A	This alarm occurs when the SCADA PLC UPS has lost power. Go to the station and assess the problem. Call in the appropriate person in to repair the problem.
UPS Operating	N / A	This occurs when the SCADA PLC is operating on the UPS and not ComEd power. This alarm should go away when power is restored. If it doesn't, see (120 Volt Power Fail)

Lift Station Communication Fail Priority List

1. **Morgan Creek**
2. **North Aurora**
3. **Sugar Grove**
4. **Jefferson**
5. **Rt. 25**
6. **Oswego**
7. **North Ave**
8. **Orchard Rd**
9. **ILL Ave**
10. **Farnsworth**
11. **Reckinger**
12. **Cedar Glenn**

CSO – The CSO is Only Critical During High Flows (Rain)

Always Make Sure That Lift Stations 1 Thru 7 Are Working First

Before Checking The CSO