

NOTES

- 3" or 4" plain end connections
- Unit weight - w/cast iron cover: 148 lbs.; w/composite covers: 93 lbs. (For wet weight add 542 lbs.)
- Maximum operating temperature: 150° F continuous
- Capacities - Liquid: 65 gal.; Grease: 439.5 lbs. Solids: 13 gal.
- This unit does not require flow control. For gravity drainage applications only.
- Do not use for pressure applications.
- Cover placement allows full access to tank for proper maintenance.
- Vent not required unless per local code.
- Engineered inlet and outlet diffusers are removable to inspect / clean piping.
- Integral air relief / Anti-siphon / Sampling access.
- Adjustable cover adapters provide up to 4" of additional height.
- Flow rate is based on 2-minute drain time.
- Safety Star™, access restrictor built into each cover adapter, prevents accidental entry to tanks (450 lb rating)

ENGINEER SPECIFICATION GUIDE

Schier Great Basin™ grease interceptor model # GB-50 shall be lifetime guaranteed and made in USA of seamless, rotationally-molded polyethylene. Interceptor shall be furnished for above or below grade installation. Interceptor shall be certified to ASME A112.14.3 (Type D) and CSA B481.1, with adjustable cover adapter, Safety Star® access restrictor built into cover adapter, and three outlet options. Interceptor flow rate shall be 50 GPM. Interceptor grease capacity shall be 439.5 lbs. Cover shall provide water/gas-tight seal and have minimum 16,000 lbs. load capacity.

Options

- C24HP - H20 Load rated pickable cast iron cover (**Required if unit is installed exterior of the building**)
- C24H2 - Composite Cover (**Required if unit is installed interior of the building**)
- 3" Plain end connections
- 4" Plain end connections

Accessories

- FCR2 - Field cut riser
- CC2 - Clamping collar kit
- PP3 - Pump out port kit
- AK1 - Anchor Kit

BELOW GRADE INSTALLATION INSTRUCTIONS

EXCAVATION

- Locate unit as close as possible to fixtures being served.
- Width and length of excavation shall be minimum 12" greater than the tank on all sides and ends.
- Depth of excavation shall be 6" deeper than tank bottom.
- Per Fox Metro requirements, minimum of 42" of cover and a minimum of 1.00% slope is required for all exterior 4" and 6" sanitary piping.
- Set the tank in well-packed crushed aggregate IDOT CA #7 backfill material approximately 3/4" size rock with no fines.
- The need for an anchor due to high water table conditions to prevent float out is to be determined by specifying engineer. If necessary, anchor is deemed necessary order optional "Anchor Kit".

BACKFILLING & FINISHED CONCRETE SLAB

- Preparation of sub grade per geotech recommendations.
- Stabilize and compact sub grade to 95% proctor.
- Fill tank with water before backfilling to prevent float out during piping installation.
- Before backfilling and pouring of slab secure cover(s) to the unit(s)
- Backfill using crushed aggregate IDOT CA #7 backfill material approximately 3/4" size rock with no fines.
- Place 6" aggregate base under slab. Aggregate should be IDOT CA #7
- Thickness of concrete around cover to be determined by specifying engineer. If H20 loading is required the concrete slab dimensions shown are for guideline purposes only.
- Concrete to be 28 day compressive strength to 4000 PSI.
- NO. 4 rebar (Ø 1/2") grade 60 steel per ASTM A615: connected with tie wire.
- Rebar to be 2 1/2" from edge of concrete.
- Rebar spacing 12" grid, 4" spacing around access openings.
- All penetrations to be sleeved or have slip connections.

CONNECTIONS

- Connect waste piping to the unit with Non-Shear coupling.

ON THE FLOOR INSTALLATION

NOTES

- Installation of Great Basin units indoors allowed only with written consent of Fox Metro Water Reclamation District.

Fox Metro Water Reclamation District Notes:

- For exterior installations, dual manway units required in Fox Metro's service area. No venting is required.
- 6" units shall be installed when the proposed design indicates 6" piping upstream and downstream. 4" connections are only used when a 4" sewer exits the building, passes through the unit, and then re-joins the 4" internal building drain.
- All external pipe connections shall be made with non-shear couplings.
- Min. of 3.5' of cover and 1% slope for all external piping.
- CA-7 Class 1A stone 6" under and 1' over all external piping.
- Only H20 (min.) load-rated cast iron lids and frames with concealed pick holes and watertight gaskets are allowed.

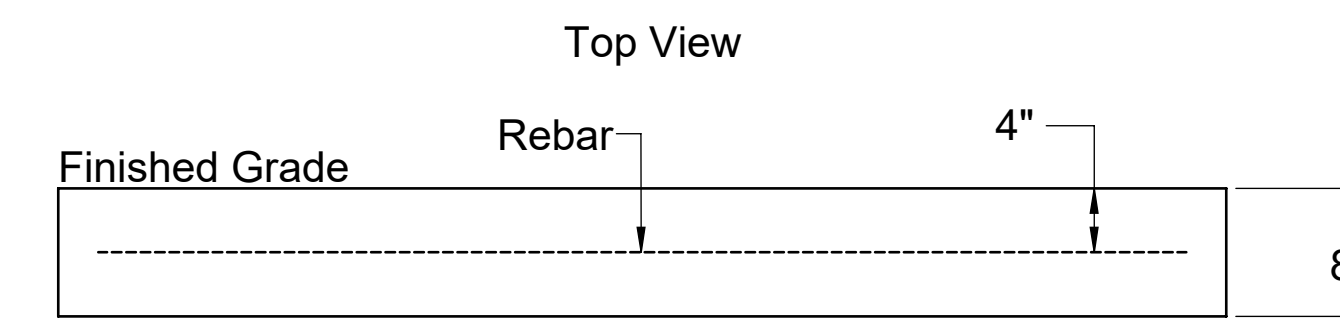
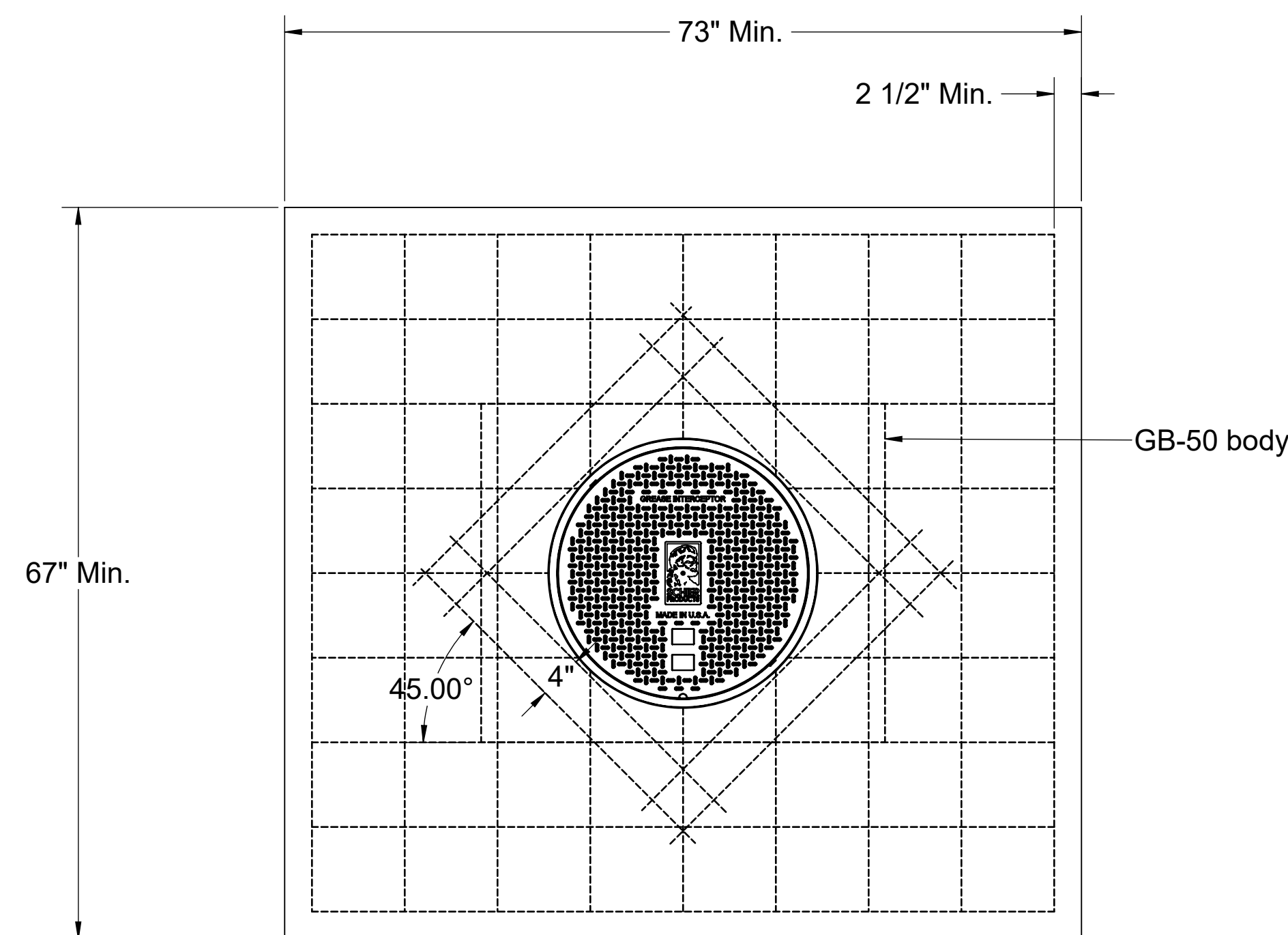

Concrete Slab Detail for H20/HS20 Loading

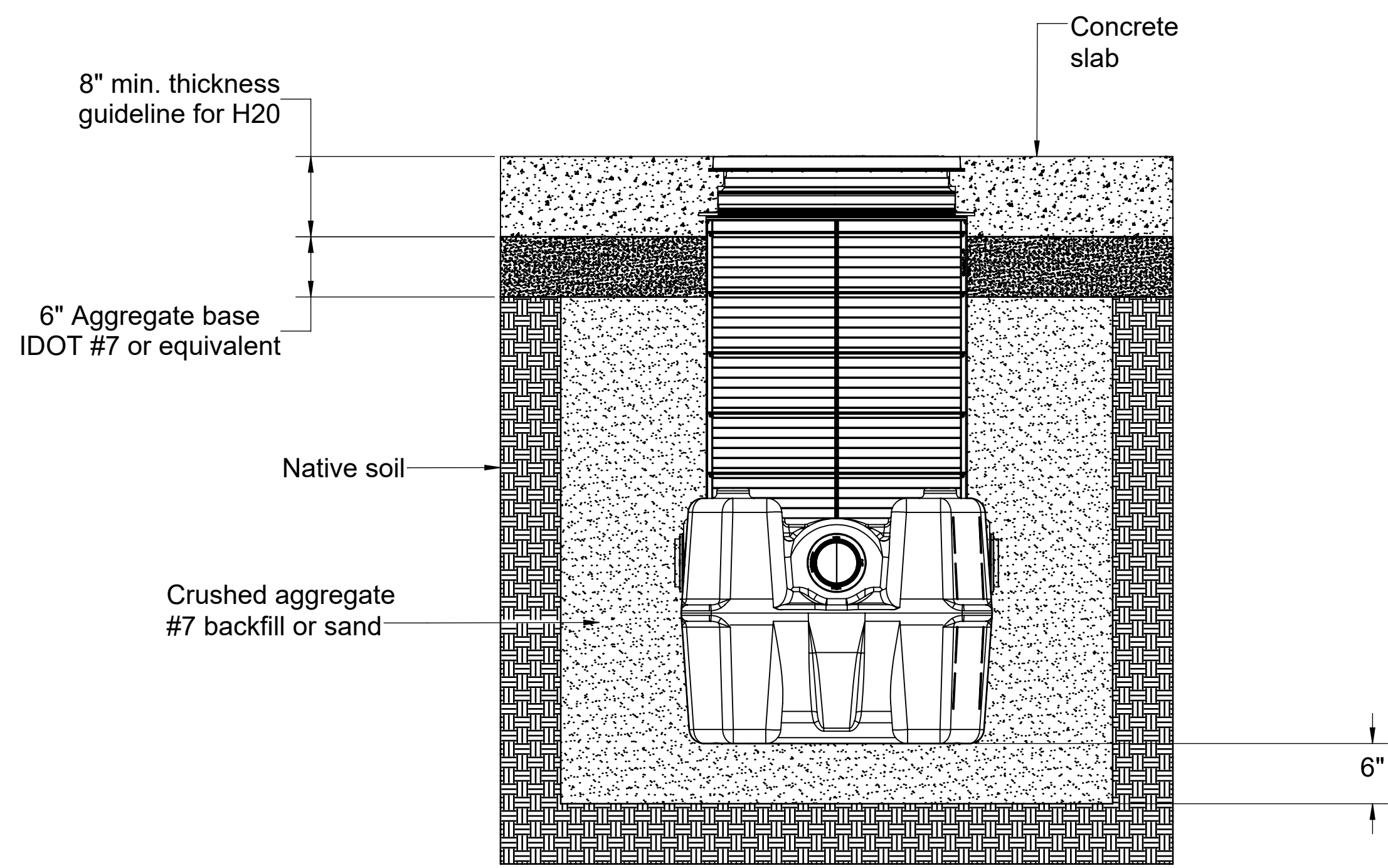

Excavation and Backfill Detail

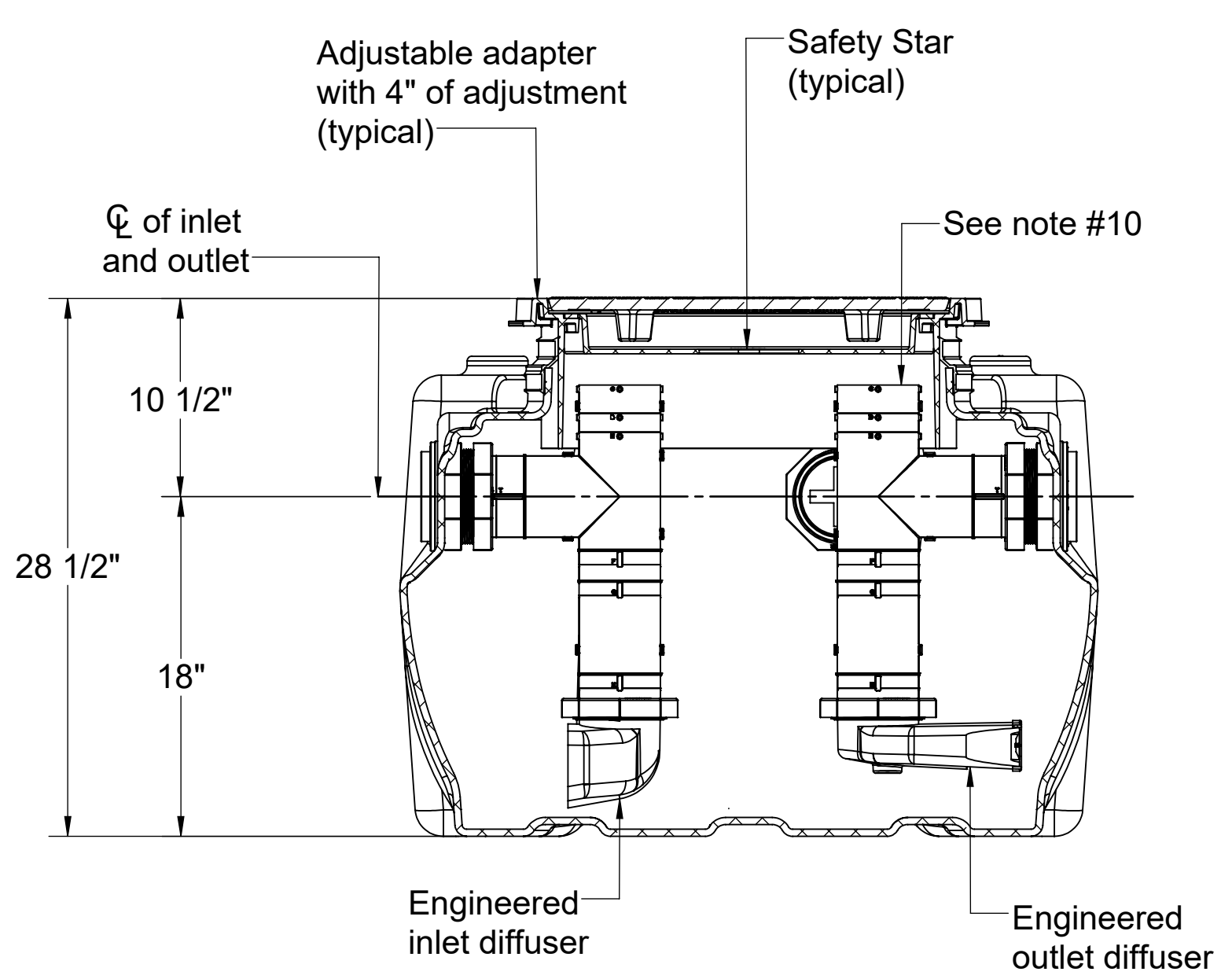
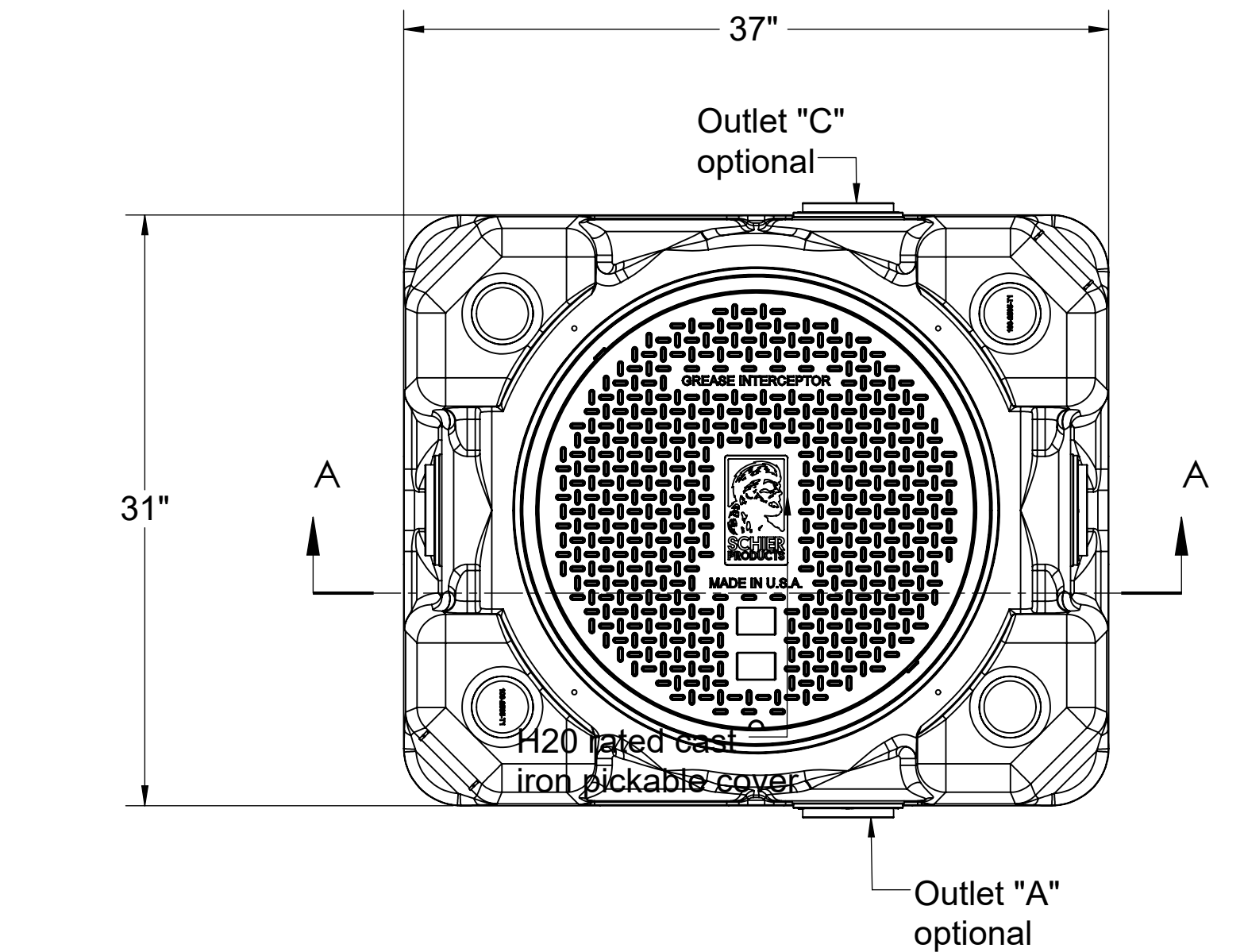

SECTION A-A SCALE 1 : 8

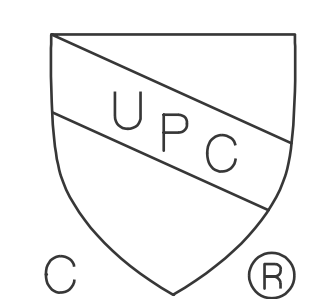

DESCRIPTION: Schier Great Basin Grease Interceptor Model GB-50, Flow rate 50 GPM, 439 Pound Grease Capacity, 65 Gal Liquid Capacity 4" or 3" Fittings Fox Metro Wastewater Detail		
MODEL NUMBER: GB-50	DOCUMENT No. : 900-0229-01	
DWG BY: TEU	DATE: 2/10/21	REV: 3 - 9/28/22

Schier Products
6455 Woodland Drive
Shawnee, KS 66218
Tel: 913-951-3300
www.schierproducts.com
Made in the U.S.A



SPECIFICATION SHEET