

REVISIONS				
ZONE	REV	DESCRIPTION	DATE	APPROVED
ALL	0	RELEASE	DATE	JG

SUPER-1500

1. Inlet and Outlet No-Hub Connections.
2. Liquid Holding Capacity: 1500 Gallons
3. H2O Load Rated Access Covers
4. Maximum Operating Temperature: 190° Continuous

DETAILS

- Certified by CSA and IAPMO to ASME A112.14.3, CSA B481, and ANSI Z1001
- Approved installation to ASME A112.14.3 Type C
- Factory installed internal piping.
- 3/8" thick seamless high density polyethylene.
- Full internal access through lids.
- Vent not required for proper operation.
- Designed for above or below ground installations.
- Integral Anti-siphon Air Relief port.

SUFFIX

- | | |
|------|-----------------------------------|
| -AK | High water anchor kit |
| -C | Lid extension(specify) |
| -DP | Dosing pump |
| -EP | Enzyme port |
| -F6 | 6" No Hub inlet/outlet connection |
| -HLA | High level alarm |

OPTIONAL VARIATIONS

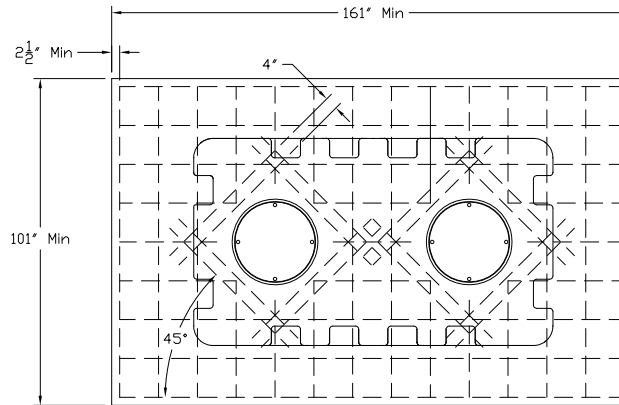

CONCRETE SLAB DETAIL FOR
H2O/HS20 LOAD RATING

INSTRUCTIONS FOR BELOW GRADE INSTALLATION

EXCAVATION

1. Install the interceptor(s) as close as practical to the fixtures being served.
2. The excavation must be a minimum of 18" greater on all sides of the tank.
3. The depth of the excavation must be greater than 12" on the bottom of the interceptor.
4. Fill the interceptor with water prior to backfilling in order to prevent the interceptor from floating.
5. Fully install the double wall corrugated pipe and lid prior to backfilling.
6. Concrete or finishing material requirements is to be determined by the specifying engineer.
7. Encase the interceptor in well-packed 3/4" rock, or sand. Do not compact backfill around interceptor.
8. To prevent float out, the Anchor kit is recommended for installations in high water table conditions. This is to be determined by the specifying engineer.

NOTES:

- Concrete to be 28 day compressive strength to 4000psi.
- No. 4 rebar (1/2"Ø) grade 60 steel per ASTM A615 connected with wire
- Rebar to be 4" from face of concrete.
- Rebar spacing 12" grid, 4" spacing around access openings.
- All penetrations to be sleeved or have slip connections.
- Minimum 18" from top of slab to top of tank.
- A minimum of 3.5' of coverage and 1.00% slope is required for all external piping.
- Unit can be installed above grade in an external environment. Frost proof requirements for installation region should be followed.
- Either 4" or 6" internal piping may be required in Fox Metro's service area. Refer to approved plans for sizing of the downstream sewer (4" or 6").

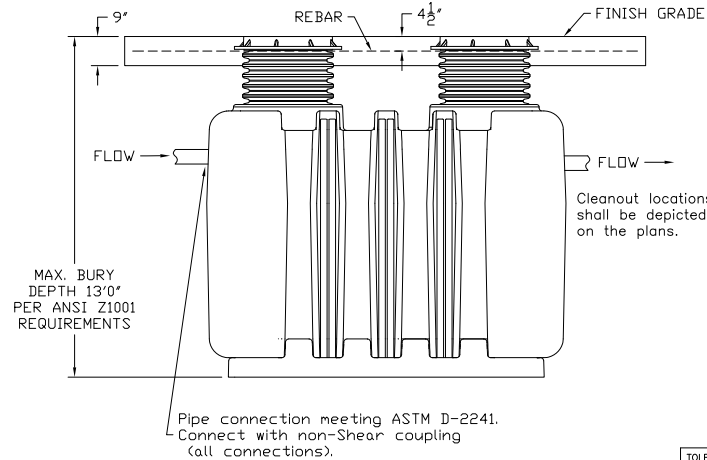
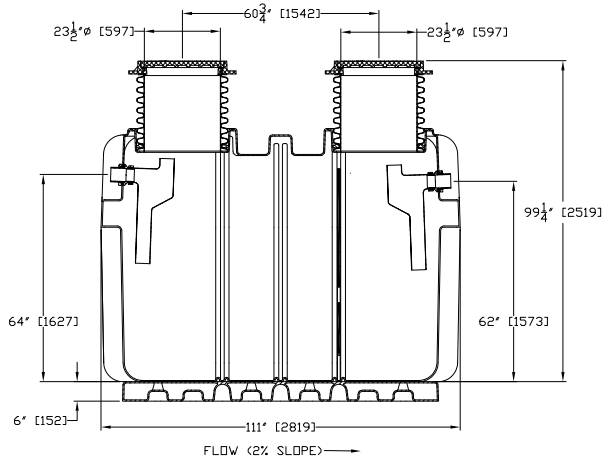

TOLERANCES (UNLESS OTHERWISE SPECIFIED)

- .X ± .03
- .XX ± .015
- .XXX ± .010
- ∠ ± 1°

TYP. DRAFT ANGLE = 2°

DRAWN BY JG

APPROVED BY JG



**SUPERMAX INTERCEPTOR
SUPER-1500**

SIZE C	COLOR/FINISH ---	DWG NO. SUPER-1500	REV 0
SCALE ----	MAT'L ---	SHEET 1 of 1	